

Dragonfly[®]2

FLEXIBLE + FULL-FEATURED

- **IEEE-1394a (FireWire) digital camera**
- **On-board color processing**
- **1/3" Sony[®] CCDs, BW or Color**
- **Enclosed or remote head options available***

The Dragonfly[®]2 is a flexible, full-featured IEEE-1394a (FireWire) camera designed for imaging product development.

Models	Lense Specification
DR2-BW/COL-XX	Sony 1/3" CCD, BW / Color, 648x488 at 60 FPS
DR2-HIBW/HICOL-XX	Sony 1/3" CCD, BW / Color, 1032x776 at 30 FPS
DR2-13S2M/C-CS	Sony 1/3" CCD, BW / Color, 1296x964 at 20 FPS
DR2-03S2M/C-EX-CS	Sony 1/3" CCD, BW / Color, 648x488 at 60 FPS
DR2-08S3M/C-EX-CS	Sony 1/3" CCD, BW / Color, 1032x766 at 30 FPS

Triggering and GPIO

The Dragonfly2 has an 8-pin GPIO connector located on the back of the camera and case. Inputs can be configured to accept an external trigger signal. Outputs can be configured to send an output signal, strobe or PWM signal and can drive most TTL devices at approximately 10mA. The Dragonfly2 has a logic level serial port with a bandwidth capacity of up to 115.2 Kbps.

Region of Interest (ROI) & Pixel Binning

The Dragonfly2 supports Format_7 custom image modes such as pixel binning and region of interest (ROI) to achieve faster frame rates and higher sensitivity. (Example below uses a DR2-BW)

Mode	Resolution	FPS	Description
0	648x488	60	Region of Interest (ROI)
1	320x240	100	2x2 pixel binning
2	640x240	60	1x2 pixel binning

Software

The FlyCapture[®] software development kit (SDK) is included with all Point Grey imaging products. The SDK is compatible with Microsoft Windows and includes a camera device driver, full software library with Application Programming Interface (API), demo programs and C/C++ example source code. The Dragonfly2 is also compatible with many third-party software packages from vendors such as National Instruments, Cognex, MVTec, A&B Software, Matrox, Mathworks, and Norpix.

Updatable Firmware

The field-programmable gate array (FPGA) chip controls all camera functionality, including exposure, resolution and frame rate, pixel binning, user memory channels and more. It can also be updated with new functionality in the field.

*not available for DR2-13S2M/C-CS models

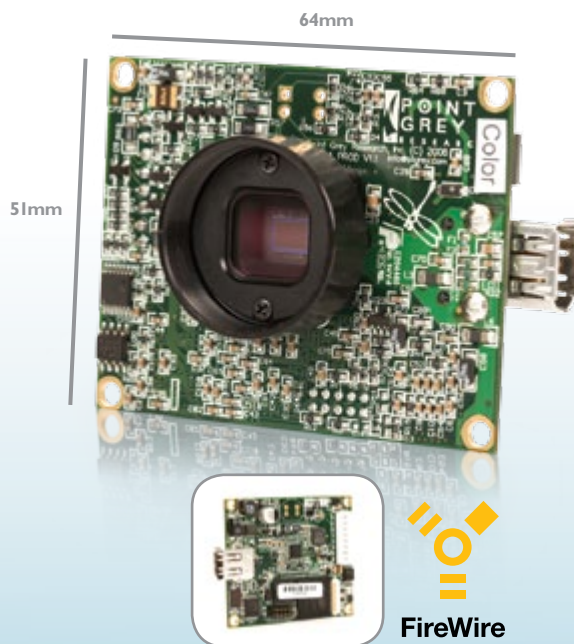

Automatic Synchronization

Multiple Dragonfly2 cameras networked on the same IEEE-1394 bus are automatically synchronized to each other. The maximum deviation between cameras is 125µs.

Color Processing

The color Dragonfly2 features on-camera color processing and auto white balance. Available outputs include YUV411, YUV422 and RGB. If a reduction in the bus bandwidth is required, users can access the raw Bayer pattern.

Auto Iris

In addition to auto-gain and auto-shutter/exposure controls, the Dragonfly2 has a DC auto-iris output. Using standard CCTV auto-iris lenses, users can physically control the amount of light that falls onto the CCD. This feature is particularly important in outdoor applications where the amount of light can vary greatly.

Gamma and Programmable LUT

The digitization of the images on the camera is achieved using a 12-bit analog to digital converter. Users can choose either an 8-bit or 16-bit output from the camera. Gamma can be applied to 12-bit data when 8-bit output is used. Lookup table support (LUT) is also available for custom mapping of image values.

On-Board Memory Channels

The Dragonfly2 has the ability to save and restore camera settings and imaging parameters via on-board memory channels. This is useful for saving default power-up settings, such as gain, shutter, video format and frame rate, etc., that are different from the factory defaults.

Dragonfly[®]2 Specifications

Specification	BW/COL/03S2	HIBW/HICOL/08S2	I3S2
Image Sensor Type	Sony [®] 1/3" progressive scan CCDs		
Image Sensor Model	ICX424	ICX204	ICX445
Sensor Pixel Size	7.4µm square pixels	4.65µm square pixels	3.75µm square pixels
Maximum Resolution	648x488	1032x776	1296x964
Maximum Frame Rate	648x488 at 60 FPS	1032x776 at 30 FPS	1296x964 at 20 FPS
Lens Mount	C/CS-mount, M12 microlens		C/CS-mount
A/D Converter	Analog Devices 12-bit analog-to-digital converter		
Video Data Output	8, 16 and 24-bit digital data		
Partial Image Modes	Pixel binning and region of interest modes via Format_7		
Interfaces	6-pin IEEE-1394 for camera control and video data transmission 8 general purpose digital input/output (GPIO) pins		
Power Requirements	8-30V, max 2W at 12V		max 2.2W at 12V
Gain	Automatic/Manual/One-Push Gain modes 0dB to 24dB		
Shutter	Automatic/Manual/One-Push/Extended Shutter modes 0.01ms to 66.63ms at 15 FPS, greater than 5s in extended mode		
Gamma	0.50 to 4.00		
Trigger Modes	DCAM v1.31 Modes 0, 1, 3, 4, 5 and 14		Modes 0, 1, 3, 14
Signal To Noise Ratio	Greater than 60dB at 0dB gain		
Dimensions	64mm x 51mm (bare board w/o case or lens holder)		
Mass	45 grams (bare board w/ lens holder and C-mount adapter)		
Camera Specification	IIDC 1394-based Digital Camera Specification v1.31		
Emissions Compliance	Complies with CE rules and Part 15 Class A of FCC Rules		
Operating Temp.	Commercial grade electronics rated from 0° to 45°C		
Storage Temperature	-30° to 60°C		
Remote Head Option	Available with 6-inch shielded ribbon cable	Not available	
Case Enclosed Option	Available (except with remote head option)	Not available	

Development Kit (DR2-DEVKIT) Includes:

- CS-mount lens with variable focus and auto iris
- GPIO connector for quick and easy external wiring
- 4.5 meter, 6-pin to 6-pin, IEEE-1394 cable w/ferrites
- IEEE-1394 OHCI PCI Host Adapter 3 port-400Mbps card
- FlyCapture[®] SDK (C/C++ API and device drivers) CD

OEM Kit (DR2-xxxx-OEMKIT) Includes:

- M12 microlens with 6mm focal length, M12 lens holder†
- Tripod mounting bracket
- Wiring harness for the GPIO connector
- 4.5 meter, 6-pin to 6-pin, IEEE-1394 cable w/ferrites
- IEEE-1394 OHCI PCI Host Adapter 3 port-400Mbps card
- FlyCapture[®] SDK (C/C++ API and device drivers) CD

Recommended System Configuration:

- Windows[®] XP Service Pack 1
- 512MB of RAM
- Intel[®] Pentium 4 2.0GHZ or compatible processor
- AGP video card with 128MB video memory
- 32-bit PCI slot for IEEE-1394 PCI card
- Microsoft[®] Visual C++ 6.0 (to compile and run example code)

† Not compatible with DR2-13S2M/C-CS camera models

Dimensional Drawings - DR2-xxxx-CS

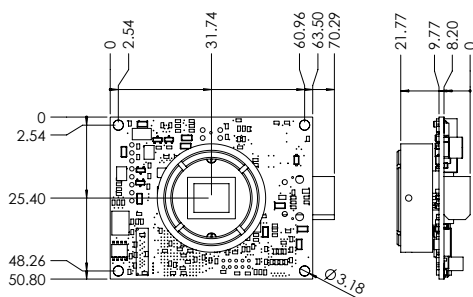

M12 Lens Mount Drawing

This mount is used for attaching an M12 microlens to the camera board.

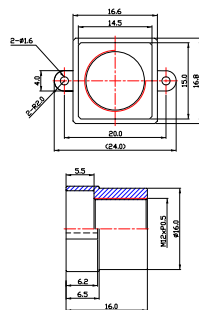

Dimensional Drawings - DR2-xxxx-CSBOX

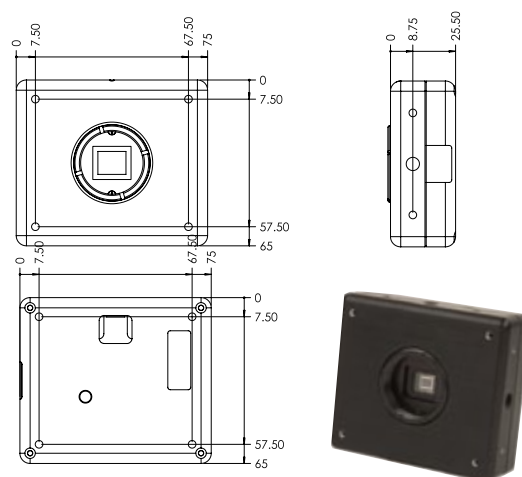

Dimensional Drawings - DR2-xxxx-EX-CS

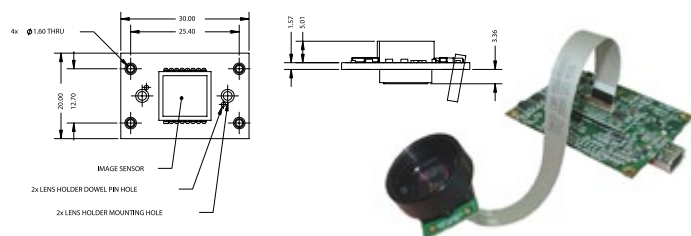

Sept 2009