

Grasshopper[®]



HIGH RESOLUTION + HIGH FPS + COMPACT

- **0.3M, 1.4M, 2.0M, or 5.0M pixels**
- **Progressive scan Sony[®] CCDs**
- **High speed 14-bit A/D converter**
- **Dual IEEE-1394b ports for daisy chaining**
- **Industry standard design, compact case**

The Grasshopper digital camera line from Point Grey Research is a complete, cost effective and reliable imaging solution. A variety of large format, high resolution image sensors, combined with an IEEE-1394b 800Mb/s interface, makes the Grasshopper an ideal choice for demanding imaging applications such as semiconductor inspection and high-speed assembly.



Specification	GRAS-03K2M/C	GRAS-03S3M	GRAS-14S3M/C	GRAS-14S5M/C	GRAS-20S4M/C	GRAS-50S5M/C
Image Sensor Type	Kodak (K) and Sony (S) progressive scan interline transfer CCD's with square pixels and global shutter					
Image Sensor Model	KAI-0340D 1/3"	ICX414 1/2"	ICX267 1/2"	ICX285 2/3" (EXView HAD)	ICX274 1/1.8"	ICX625 2/3" (Super HAD)
Maximum Resolution	640(H) x 480(V)	648(H) x 488(V)	1384(H) x 1032(V)	1384(H) x 1036(V)	1624(H) x 1224(V)	2448(H) x 2048(V)
Pixel Size	7.4µm x 7.4µm	9.9µm x 9.9µm	4.65µm x 4.65µm	6.45µm x 6.45µm	4.40µm x 4.40µm	3.45µm x 3.45µm
Analog-to-Digital Converter	Analog Devices 14-bit ADC					
Video Data Output	8, 12, 16 and 24-bit digital data					
Image Data Formats	Y8, Y16 (all models), RGB, YUV411, YUV422, YUV444, 8-bit and 16-bit raw Bayer data (color models)					
Digital Interface	Dual Bilingual 9-pin IEEE-1394b for camera control, video data transmission, and power					
Transfer Rates	100, 200, 400, 800 Mbit/s					
Maximum Frame Rate ¹	640x480 at 200 FPS	648x488 at 74 FPS	1384x1032 at 21 FPS	1384x1036 at 15 FPS	1624x1224 at 30 FPS	2448x2048 at 15 FPS
Partial Image Modes	pixel binning and region of interest modes via Format_7					
General Purpose I/O Ports	8-pin Hirose HR25 general purpose input/output connector 4 pins for external trigger, strobe or RS232 / 1 pin +3.3V / 1 VEXT pin to externally power the camera					
Gain Control	automatic / manual / one-push gain modes, programmable via software 0dB to 24dB in 0.04dB increments					
Shutter Speed	automatic / manual / one-push modes, programmable via software 0.02ms to greater than 10s (extended shutter mode)					
Synchronization	via external trigger, software trigger (on same bus only), or free-running					
External Trigger Modes	DCAM v1.31 Trigger Modes 0, 1 (bulb shutter), 3, 14 (overlapped trigger and transfer), and 15 (multi-shot trigger)					
Voltage Requirements	8-30V, via the IEEE-1394b interface or Hirose 8-pin GPIO connector					
Power Consumption	2.9W	2.9W	3.0W	3.1W	3.4W	3.8W
Dimensions (L x W x H)	58mm x 44mm x 29mm (not including lens holder and GPIO connector)					
Mass	104g (without optics)					
Camera Specification	IICD 1394-based Digital Camera Specification v1.31, compatible with IEEE-1394b and IEEE-1394a interfaces					
Lens Mount	C-mount					
Emissions Compliance	Complies with CE rules and Part 15 Class A of FCC Rules					
Operating Temperature	0° to 40°C					
Storage Temperature	-30° to 60°C					
Vibration Resistance	10 G (14 Hz to 200 Hz)					
Warranty	2 year					

¹ Maximum frame rate at full resolution achieved using Format 7

Grasshopper[®] Specifications

IEEE-1394b Benefits

The IEEE-1394b 800Mb/s bus provides reliable, deterministic communication with guaranteed bandwidth. This allows full color images to be transmitted at faster frame rates, and more cameras to be networked on the same 1394b bus. The Grasshopper camera family is also backward compatible with 1394a and can work seamlessly with legacy 1394a systems¹.

Daisy Chaining

Multiple Grasshopper cameras can be daisy chained together using the dual IEEE-1394b ports on the back, effectively minimizing cabling requirements and equipment costs and maximizing the reliability of the data pipeline.

Secure and Powered

Screw holes located on either side of the Grasshopper camera's IEEE-1394b connectors enable the locking 1394b cable (included in the Development Accessory Kit) to be securely connected to the camera. This not only guarantees a reliable connection, but also reduces stress on internal electronics that can be caused by cable movement. The cable also carries both data and power, minimizing the need for additional cables or external power sources.

Industry Standard Design

Every mechanical component of the Grasshopper camera is designed to maximize usability, including the compact aluminum case, C-mount lens holder and ASA/ISO-compliant tripod mounting bracket, status LED and removable glass/IR filter system.

Dimensional Drawings (in mm)

CAD models available at www.ptgrey.com/support/downloads.

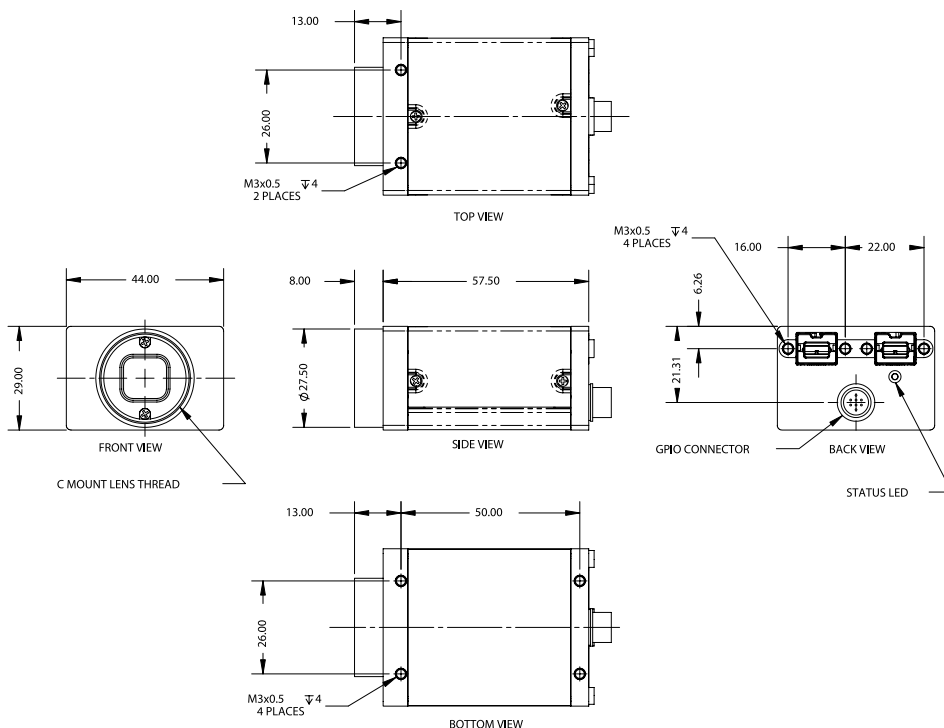

Frame Buffer/Image Retransmit

The camera is equipped with a 32MB frame buffer that can be used to store multiple images for transmission, or retransmission, at a later time. This is useful in situations where the available 1394b bandwidth must be maximized between multiple cameras, or where an image must be sent again.

Updatable FPGA

The field-programmable gate array chip controls all camera functionality, including on-camera color processing, pixel binning, automatic inter-camera synchronization, user memory channels and more. It can also be updated with new functionality in the field.

Software

The FlyCapture[®] SDK is compatible with Microsoft[®] Windows[®] and includes the PGR CAM™ device driver, full software API library, demo programs and C/C++ example source code. It also includes the FirePRO™ driver, which provides enhanced debugging and diagnostics and allows 1394b devices to run at 800Mb/s.

Development Accessory Kit (DEVKIT-01-0001 & DEVKIT-01-0002)

This kit has all the hardware and software you need for rapid design and prototyping, including:

- 4.5 meter, 9-pin to 9-pin, 1394b locking cable
- 4.5 meter, 6-pin to 9-pin, 1394a to 1394b locking cable
- IEEE-1394b OHCI PCI Host Adapter 3-port 800Mb/s card (DEVKIT-01-0001)
- FirePRO low profile single bus IEEE-1394b PCI Express card (DEVKIT-01-0002)
- Male GPIO connector prewired for quick and easy access
- FlyCapture[®] SDK (C/C++ API and device drivers) CD