

CHAMELEON SPECIFICATIONS

SPECIFICATION	CMLN-13S2M/C
Image Sensor Model	Sony progressive scan interline transfer ICX445 1/3" EXview HAD CCD™
Maximum Resolution	1296(H) x 964(V)
Pixel Size	3.75µm x 3.75µm
A/D Converter	Analog Devices 12-bit ADC
Video Data Output	8 and 16-bit digital data
Image Data Formats	Y8, Y16 (monochrome), 8-bit and 16-bit Bayer data (color models)
Digital Interface	5-pin Mini-B USB 2.0 digital interface for camera control, video data transmission, and power
Data Transfer Rate	480Mbps/s
Maximum Frame Rate	1296x964 Y8 at 18FPS
Partial Image Modes	pixel binning and region of interest modes via Format_7
General Purpose I/O	7-pin JST GPIO connector, 4 pins for trigger and strobe, 1 pin +3.3 V, 1 V _{EXT} pin for external power
Gain	auto / manual / one-push gain modes, programmable via software, 0 dB to 24 dB in 0.04 dB increments
Shutter	auto / manual / one-push modes, programmable via software, 0.01 ms to greater than 10 s (extended shutter mode)
Synchronization	via external trigger
Trigger Modes	DCAM v1.31 Trigger Modes 0, 1 (bulb trigger), 3, and 14 (overlapped trigger and transfer)
Memory Storage	3 memory channels for custom camera settings
Power Requirements	4.745 to 5.25 V via the Mini B USB 2.0 interface or JST 7-pin GPIO connector
Power Consumption	2 W (max) at 5 V
Dimensions (DxWxH)	25.5 mm x 41 mm x 44 mm (excluding optics)
Mass	37 grams (including tripod mounting bracket)
Lens Mount	CS-mount (5mm C-mount adapter included)
Emissions Compliance	Complies with CE rules and Part 15 Class B of FCC Rules
Temperature	0° to 45°C(Operating), -30° to 60°C(Storage)
Warranty	1 year

IMAGE ACQUISITION

USB 2.0 Bandwidth	480 Mb/s interface
Programmable Exposure	User-programmable shutter and gain settings via software
Fast Frame Rates	Faster standard frame rates, pixel binning and ROI support
Multiple Trigger Modes	Bulb-trigger mode
Trigger at Full Frame Rate	Overlapped trigger input, image acquisition and transfer
Embedded Image Info	Pixels contain frame-specific info

CAMERA AND DEVICE CONTROL

Frame Rate Control	Fine-tune frame rates for video conversion (e.g. PAL @ 24 FPS)
Memory Channels	Non-volatile storage of camera default power-up settings
Camera Upgrades	Firmware upgradeable in field via USB 2.0 interface.

MECHANICS AND FORM FACTOR

Ultra-Compact Design	Small (25.5mm x 41mm x 44mm) and light (37g)
Industry Standard Design	ASA/ISO-compliant mounting bracket and CS-mount lens holder

STATUS LED

LED STATUS	DESCRIPTION
Off	Not receiving power
Steady on	Receiving power and successful camera initialization
Steady on and very bright	Acquiring / transmitting images
Flashing bright, then brighter	Camera registers being accessed (no image acquisition)
Steady flashing on and off	Indicates possible camera problem
Slow flashing on and off	Indicates possible camera problem

CAMERA INTERFACE

USB 2.0 CONNECTOR

The Chameleon has a USB 2.0 Mini-B vertical connector (pin configuration shown below) that is used for data transmission, camera control and powering the camera. For more detailed information, consult the USB 2.0 specification available from <http://www.usb.org/developers/docs/>.

CABLES

The maximum cable length between any USB mode (e.g. camera to USB, USB to hub, etc.) is 5.0m, as specified by the USB specification. Standard, shielded twisted pair copper cables must be used.

GENERAL PURPOSE INPUT/OUTPUT (GPIO)

The Chameleon has a 7-pin GPIO connector on the back of the case. The connector is made by JST (Mfg P/N: BM07B-SR5S-TB). The Development Kit contents include a pre-wired female connector; refer to the diagram below for wire color-coding. Additional female connectors (Mfg P/N: SHR-07V-S-B) can be purchased from Digikey (P/N: 455-1382-ND).

Diagram	Pin	GPIO	Function
	1	VEXT	Power camera externally, Voltage limit: 4.75 to 5.25V
	2	+3.3V	Power external circuitry up to a total of 150mA
	3	IO0	Input / Output (default Trigger_Src)
	4	IO1	Input / Output
	5	IO2	Input / Output
	6	IO3	Input / Output
	7	GND	Input / Output

Inputs can be configured to accept external trigger signals. Outputs can be configured to send an output signal or strobe pulse. Refer to the Chameleon Technical Reference for detailed GPIO electrical characteristics.

STANDARD IMAGE FORMATS

Mode	Frames Per Second				
	1.875	3.75	7.5	15	30*
640x480 Y8	●	●	●	●	●
640x480 Y16	●	●	●	●	●
1280x960 Y8	●	●	●	●	●
1280x960 Y16	●	●	●	●	●

*Black and white output only. Color data is removed due to pixel binning.

Getting Started

CHAMELEON™ USB 2.0 Digital Camera

The following items are included with your Chameleon Development Accessory Kit (DEVKIT-01-0003)

- 2 meter USB 2.0 cable (Type A to Mini-B 5-pin)
- ACC-01-3002 GPIO wiring harness
- Chameleon Getting Started Manual
- FlyCapture SDK CD

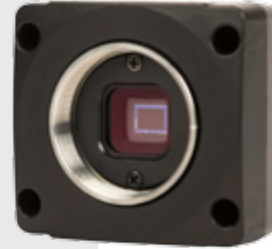

April 2011

POINT GREY
Innovation in Imaging

TECHNICAL DRAWINGS

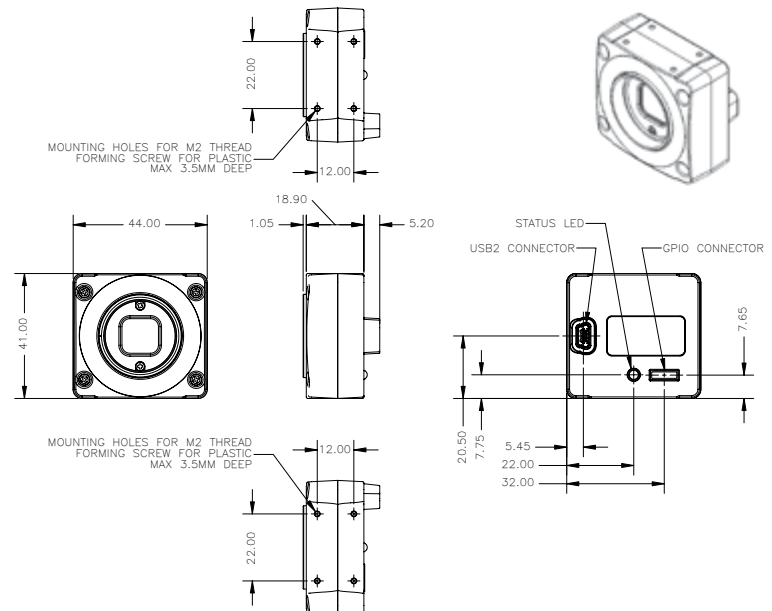

SPECTRAL RESPONSE (QE)

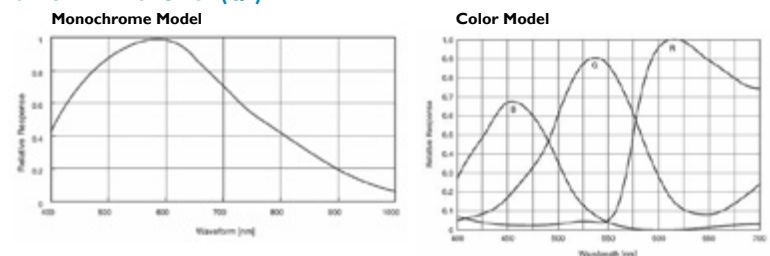

1 Installation

I. Recommended System Configuration

OS	CPU	RAM	VIDEO	PORTS
Windows XP SP1	2.0GHz or equivalent	512mb	AGP 128mb	USB 2.0

- Windows XP Service Pack I
- 512MB of RAM
- Intel Pentium 4 2.0GHz or compatible processor
- AGP video card with 128MB video memory
- USB 2.0 port
- Microsoft Visual C++ 6.0 (to compile and run example code)

2. Electrostatic Precautions and Camera Care

- Users who have purchased a bare board camera should:



- This product is not intended for use in residential environments.
- Either handle bare handed or use non-chargeable gloves, clothes or material. Also use conductive shoes.
- Install a conductive mat on the floor or working table to prevent the generation of static electricity.



- When handling the camera unit, avoid touching the lenses. To clean the lenses, use a standard camera lens cleaning kit or a clean dry cotton cloth. Do not apply excessive force.
- This device complies with Part 15 of the FCC Rules. Operation is subject to the following two conditions: (1) This device may not cause harmful interference, and (2) this device must accept any interference received, including interference that may cause undesirable operation. This Class A digital apparatus complies with Canadian ICES-003. Cet appareil numérique de la classe B est conforme à la norme NMB-003 du Canada.

- To clean the imaging surface of your CCD, follow the steps outlined in www.ptgrey.com/support/kb/index.asp?a=4&q=66.
- Extended exposure to bright sunlight, rain, dusty environments, etc. may cause problems with the electronics and the optics of the system.
- Avoid excessive shaking, dropping or mishandling of the device.

2 Installation

3. Install the FlyCapture® Software and Drivers

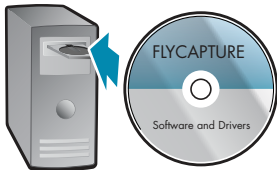

- Insert the software CD-ROM. If the Installation Wizard does not automatically run, browse to your CD-ROM directory and run setup.exe.
- Follow the installation instructions to install the software.

4. Installing the Tripod Adapter (optional)

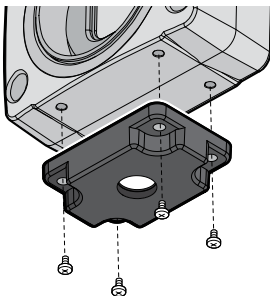

- The ASA and ISO-compliant tripod adapter for the Chameleon attaches to the camera using the included M2x3.5 screws.

5. Connect the Camera to the USB 2.0 port

- Plug the 2-meter USB 2.0 cable (Type A to Mini-B 5-pin) into the host machine's USB 2.0 port and the Chameleon connector.
- If the Microsoft Windows "Found New Hardware Wizard" appears, proceed to Step 6. Otherwise, proceed to Step 7.

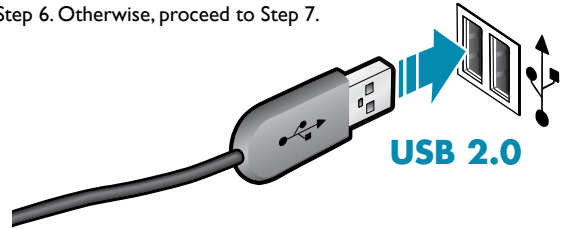

6. Install the PGRUSBCam Driver

- Click "Install from a list or specific location" and click "Next".
- Select "Don't search. I will choose the driver to install" and "Next".
- Click "Have Disk" and browse to **C:\Program Files\Point Grey Research\PGR FlyCapture\driver**, click "Open", then "OK".
- Select the camera model and click "Next".
- You will be prompted to continue installation - click "Continue Anyway" then "Finish" to complete installation.

7. Confirm Successful Installation

- Check the Device Manager to confirm that installation was successful (PGRUSBCam driver install only). Go to the **Start menu**, select **Run** and enter "devmgmt.msc".
- To test the camera's image acquisition capabilities, run the FlyCap demo program. From the **Start menu**, select **All Programs > Point Grey Research > PGR FlyCapture > FlyCap.exe**.

3 Troubleshooting

The FlyCapture® User Guide and other technical references can be found in the **Programs > Point Grey Research > PGR FlyCapture > Documentation** directory. Our on-line Knowledge Base (www.ptgrey.com/support/kb/) also addresses the following problems:

- Article 21: Troublesome hardware configurations
- Article 88: Vertical bleeding or smearing from a saturated portion of an image
- Article 91: PGR camera not recognized by system and not listed in Device Manager
- Article 145: Image discontinuities or horizontal tearing of images when displayed on monitor
- Article 188: Image data acquired by my camera is corrupt and displayed images are broken
- Article 189: Image capture freezes after a period of successful image capture.
- Article 197: Extending the distance between a PGR camera and the controlling host system.

CONTACTING POINT GREY RESEARCH

Email:

For all general questions about Point Grey Research please contact us at info@ptgrey.com.

For technical support (existing customers only) contact us at www.ptgrey.com/support/contact/.

Main Office:

Mailing Address:
Point Grey Research, Inc.
Richmond B.C. Canada
12051 Riverside Way
V6W 1K7

Tel: +1 (604) 242-9937
Toll Free (N.America only): +1 (866) 765-0827
Fax: +1 (604) 242-9938
Email: sales@ptgrey.com

Knowledge Base:

Find answers to commonly asked questions in our knowledge base at www.ptgrey.com/support/kb/.

Downloads:

Users can download the latest manuals and software from www.ptgrey.com/support/downloads/.

This device complies with Part 15 of the FCC Rules. Operation is subject to the following two conditions: (1) This device may not cause harmful interference, and (2) this device must accept any interference received, including interference that may cause undesirable operation.

This Class A digital apparatus complies with Canadian ICES-003. Cet appareil numérique de la classe B est conforme à la norme NMB-003 du Canada.