

TECHNICAL DRAWINGS

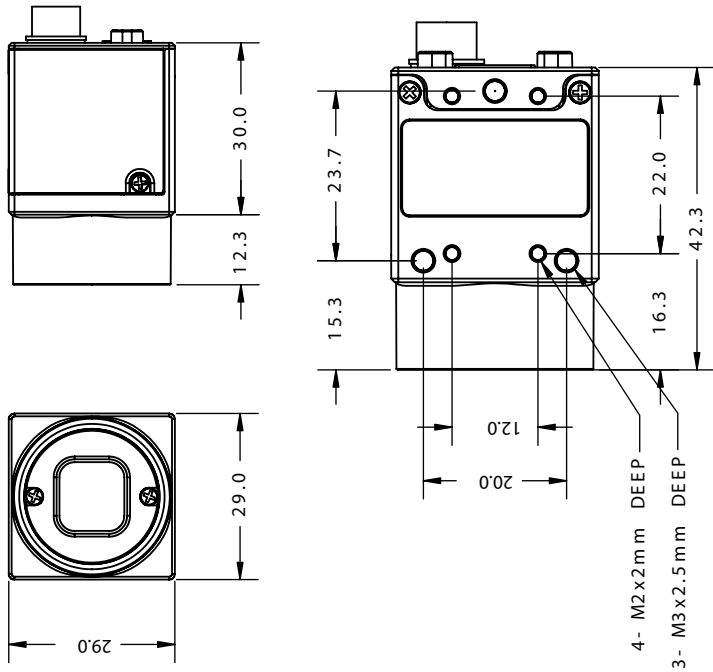

STATUS LED

Steady on	Receiving power and successful camera initialization
Steady on and very bright	Acquiring / transmitting images
Flashing bright, then brighter	Camera registers being accessed (no image acquisition)
Steady or slow flashing on and off	Camera firmware updated (requires power cycle), or possible camera problem

# Getting Started

## Flea<sup>®</sup> 2 IEEE-1394b Digital Camera



SPECIFICATIONS

	FL2-03S2	FL2-08S2	FL2-14S3	FL2-20S4	FL2G-13S2M/C	FL2G-50S5M/C
Image Sensor Type	Sony progressive scan interline transfer CCD's with square pixels and global shutter, monochrome or color					
Image Sensor Model	ICX424 1/3"	ICX204 1/3"	ICX267 1/2"	ICX274 1/1.8"	ICX445 1/3" EXview HAD CCD™	ICX655 2/3" SuperHAD CCD™
Maximum Resolution <sup>1</sup> and Max Frame Rate	648x488 at 80 FPS	1032x776 at 30 FPS	1392x1032 at 15 FPS	1624x1224 at 15 FPS	1288x964 at 30 FPS	2448x2048 at 7.5 FPS
Pixel Size	7.4µm x 7.4µm	4.65 x 4.65µm	4.65 x 4.65µm	4.4 x 4.4µm	3.75 x 3.75µm	3.45 x 3.45µm
Analog-to-Digital Converter	Analog Devices 12-bit analog-to-digital converter					
Video Data Output	8, 12, 16 and 24-bit digital data (see Supported Data Formats)					
Image Data Formats	Y8,Y16 (all models), RGB,YUV411,YUV422,YUV444, 8-bit and 16-bit raw Bayer data (color models)					
Digital Interface / Transfer Rates	Bilingual 9-pin IEEE-1394b for camera control, video data transmission, and power				Transfer Rates: 100, 200, 400, 800 Mbit/s	
Partial Image Modes	pixel binning and region of interest modes via Format_7					
Interfaces	9-pin IEEE-1394b for camera control and video data transmission, 4 general-purpose digital input/output (GPIO) pins.					
General Purpose I/O Ports	8-pin Hirose HR25 GPIO connector, opto-isolated pins for trigger and strobe (FL2G models only), bi-directional pins for trigger, strobe or serial port					
Gain Control	automatic / manual / one-push gain modes, programmable via software, 0dB to 24dB in 0.04dB increments					
Shutter Speed	automatic / manual / one-push modes, programmable via software, 0.02ms to greater than 10s (extended shutter mode)					
Synchronization	via external trigger, software trigger (on same bus only), or free-running					
External Trigger Modes	DCAM v1.31 Trigger Modes 0, 1, 3, 4 and 5 <sup>1</sup> (multiple exposure, 03S2 and 08S2 models only), 14 (overlapped trigger), and 15 (multi-shot trigger)					
Voltage Requirements	power via Vext GPIO pin or 9-pin 1394b interface: 8 to 30V, less than 2.5W					
Mass/ Dimensions (L x W x H)	58 grams (without optics), 29mm x 29mm x 30mm (excluding lens holder, without optics)					
Memory Storage	(FL2G models only) 32MB frame buffer, 512KB non-volatile data flash					
Memory Channels	3 memory channels for custom camera settings					
Gain	Automatic/Manual/One-Push Gain modes, 0dB to 24dB					
Shutter	Automatic/Manual/One-Push Shutter modes, 0.01ms to 66.63ms @ 15 FPS, Extended shutter modes for exposure times longer than 5 seconds					
Lens Mount	C-mount					
Emissions Compliance	Complies with CE rules and Part 15 Class A of FCC Rules					
Operating/Storage Temperature	0° to 45°C, -30° to 60°C					
Camera Specification	IIDC 1394-based Digital Camera Specification v1.31					

<sup>1</sup> Trigger modes 4 and 5 not supported in 14S3C or 20S4C models.

STANDARD IMAGE FORMATS

03S2C 03S2M 08S2C 08S2M 14S3C 14S3M 20S4C 20S4M 13S2C 13S2M 50S5C 50S5M

Model	Frames Per Second					
	1.875	3.75	7.5	15	30	60
160x120 YUV444	●	●	●	●	●	●
320x240 YUV422	●●●	●●●	●●●	●●●	●●●	●●
640x480 YUV411	●●●●	●●●●	●●●●	●●●●	●●●●	●●
640x480 YUV422	●●●●	●●●●	●●●●	●●●●	●●●●	●
640x480 RGB	●●●●	●●●●	●●●●	●●●●	●●●●	●●
640x480 Y16	●●●●●●	●●●●●●	●●●●●●	●●●●●●	●●●●●●	●●●●●●
640x480 Y8	●●●●●●	●●●●●●	●●●●●●	●●●●●●	●●●●●●	●●●●●●
800x600 YUV422	●●●●	●●●●	●●●●	●●●●	●●●●	●●
800x600 RGB	●●●●	●●●●	●●●●	●●●●	●●●●	●●
800x600 Y16	●●●●	●●●●	●●●●	●●●●	●●●●	●●
800x600 Y8	●●●●	●●●●	●●●●	●●●●	●●●●	●●
1024x768 YUV422	●●●	●●●	●●●	●●●	●●●	●●
1024x768 RGB	●●●	●●●	●●●	●●●	●●●	●●
1024x768 Y16	●●●●●●	●●●●●●	●●●●●●	●●●●●●	●●●●●●	●●●●●●
1024x768 Y8	●●●●●●	●●●●●●	●●●●●●	●●●●●●	●●●●●●	●●●●●●
1280x960 YUV422	●●	●●	●●	●●	●●	●●
1280x960 RGB	●●	●●	●●	●●	●●	●●
1280x960 Y16	●●●●●●	●●●●●●	●●●●●●	●●●●●●	●●●●●●	●●●●●●
1280x960 Y8	●●●●●●	●●●●●●	●●●●●●	●●●●●●	●●●●●●	●●●●●●
1600x1200 YUV422	●●	●●	●●	●●	●●	●●
1600x1200 RGB	●●	●●	●●	●●	●●	●●
1600x1200 Y16	●●●●●●	●●●●●●	●●●●●●	●●●●●●	●●●●●●	●●●●●●
1600x1200 Y8	●●●●●●	●●●●●●	●●●●●●	●●●●●●	●●●●●●	●●●●●●

NOTE: Full resolution images, maximum frame rates, and raw Bayer output (color cameras) can be achieved using Format 7. Access Format 7 modes using "Custom Image Mode" in FlyCapture.

CAMERA INTERFACE

IEEE-1394b Connector

The Flea2 has a standard 9-pin IEEE-1394b connector that is used for data transmission, camera control and powering the camera. The maximum 1394b cable length between any 1394 node (e.g. camera to PCI card) is 4.5m, as specified by the IEEE-1394 standard. Use standard, shielded twisted pair copper cables.

General Purpose I/O Connector

The Flea2 has a Hirose HR25 8-pin general purpose input/output (GPIO) female connector on the back of the case (P/N: HR25-7TR-8SA). The FL2-DEVKIT includes a one (1) meter long wiring harness equipped with a male connector (P/N: HR25-7TP-8P, Digkey P/N: HR702-ND). Wires are color coded or labeled according to the table below to indicate functionality.

Diagram	Pin	Function	Description
	1	IO0	Input / Output (default Trigger_Src) Opto-isolated Input (default Trigger in) (FL2G models only)
	2	IO1	Input / Output Opto-isolated Output (FL2G models only)
	3	IO2	Input / Output / RS232 Transmit (TX)
	4	IO3	Input / Output / RS232 Receive (RX)
	5	GND	Ground Ground for bi-directional IO, VEXT, +3.3V pins (FL2G models only)
	6	GND	Ground Ground for opto-isolated IO pins (FL2G models only)
	7	Vext	Allows the camera to be powered externally. Voltage limit: 8 to 30V, Current limit: 1A
	8	+3.3V	Power external circuitry up to a total of 150mA

To configure the GPIO pins, consult the "General Purpose Input / Output" section of the PGR IEEE-1394 Digital Camera Register Reference.

# Installation

## 1. Recommended System Configuration

OS	CPU	RAM	VIDEO	PORTS
Vista SP1, Win7, Linux Ubuntu 8.04	2.0GHz or equivalent	2 GB	AGP 128mb	IEEE-1394b

- Windows XP Service Pack 1
- 512MB of RAM
- Intel Pentium 4 2.0GHz or compatible processor
- AGP video card with 128MB video memory
- 64-bit PCI or PCI-X slot (32-bit slot required)
- PCI-Express slot
- 1394b PCI card or 1394b PCI-Express card (available in dev kit)
- Microsoft Visual C++ 6.0 (to compile and run example code)

## 2. Electrostatic Precautions and Camera Care

- Users who have purchased a bare board camera should:



- This product is not intended for use in residential environments.
- Either handle bare handed or use non-chargeable gloves, clothes or material. Also use conductive shoes.
- Install a conductive mat on the floor or working table to prevent the generation of static electricity.



- When handling the camera unit, avoid touching the lenses. To clean the lenses, use a standard camera lens cleaning kit or a clean dry cotton cloth. Do not apply excessive force.
- This device complies with Part 15 of the FCC Rules. Operation is subject to the following two conditions: (1) This device may not cause harmful interference, and (2) this device must accept any interference received, including interference that may cause undesirable operation. This Class A digital apparatus complies with Canadian ICES-003. Cet appareil numérique de la classe B est conforme à la norme NMB-003 du Canada.

- To clean the imaging surface of your CCD, follow the steps outlined in [www.ptgrey.com/support/kb/index.asp?a=4&q=66](http://www.ptgrey.com/support/kb/index.asp?a=4&q=66).
- Extended exposure to bright sunlight, rain, dusty environments, etc. may cause problems with the electronics and the optics of the system.
- Avoid excessive shaking, dropping or mishandling of the device.

## 3. Install the IEEE-1394b PCI or PCIe card

- Turn computer off and place the IEEE-1394b PCI card in an open PCI slot or place the IEEE-1394b PCI-Express card in an open PCI-Express slot.

IEEE-1394b Host Adapter 2 Port PCI card

FirePRO low profile single bus IEEE-1394b PCIe card

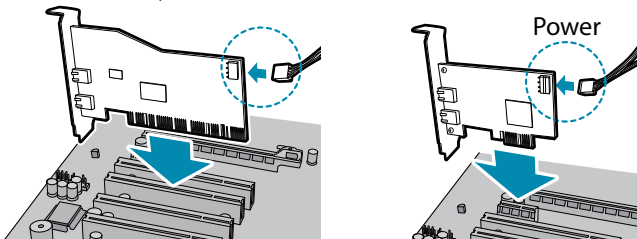

- Connect the 4-pin connector on the card to the PC power supply.
- Turn the computer back on and log into Windows.
- In most cases, the Windows IEEE-1394 drivers will be automatically installed for the card, with no user input required. However, in some cases the **Found New Hardware Wizard** will appear. Follow the prompts given by the Wizard to install the card.
- Open Windows Device Manager by going to the **Control Panel > System > Hardware tab > Device Manager**. Ensure the PCI card is properly installed as an **IEEE 1394 Bus host controller**.

## 4. Install the FlyCapture® Software and Drivers

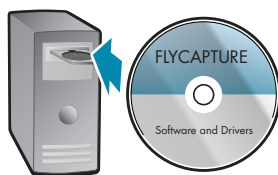

- Insert the FlyCapture software CD-ROM. If the Installation Wizard does not automatically run, browse to your CD-ROM directory and run the **setup.exe** file.

- Follow the installation instructions to install the software.



### IMPORTANT NOTE for Windows XP Users

A dialog will appear prompting you to install the **FirePRO** driver. We strongly recommend doing this in order to take full advantage of 1394b 800Mb/s speeds. See this Knowledge Base article for further information: [www.ptgrey.com/support/kb/index.asp?a=4&q=171](http://www.ptgrey.com/support/kb/index.asp?a=4&q=171)

## 5. Installing the Tripod Mounting Bracket (optional)

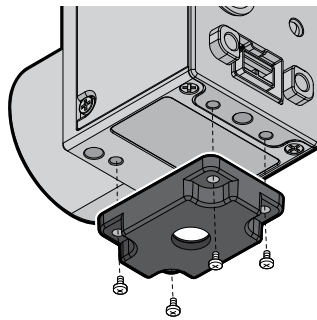

- The ASA and ISO-compliant tripod mounting bracket for the Flea2 attaches to the camera using the included M2x5 screws.

## 6. Connect the 1394b PCI Card and Cable to the camera

- Plug the 4.5 meter, 9-pin to 9-pin, IEEE-1394b cable into the 1394b PCI card and the Flea2 1394b connector; the cable jack screws can be used for a secure connection.

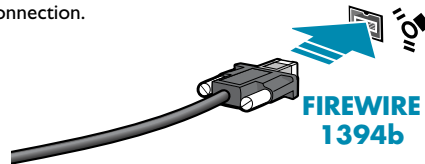

**NOTE:** The camera relies on the 9-pin 1394b cable to provide power. If using an interface card other than that provided, ensure that adequate power is provided. The Flea2 has a standard 9-pin IEEE-1394b connector that is used for data transmission, camera control and powering the camera. The maximum 1394b cable length between any 1394 node (e.g. camera to PCI card) is 4.5m, as specified by the IEEE-1394 standard

## 7. Install the GPIO Cable (optional)

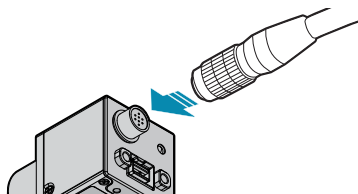

### General Purpose I/O Connector

The Flea2 has a Hirose HR25 8-pin general purpose input/output (GPIO) female connector on the back of the case (P/N: HR25-7TR-8SA). The FL2-DEVKIT includes a one (1) meter long wiring harness equipped with a male connector (P/N: HR25-7TP-8P, Digkey P/N: HR702-ND). Wires are color coded or labelled according to the table below to indicate functionality.

Diagram	Pin	Function	Description
	1	IO0	Input / Output (default Trigger_Src) Opto-isolated Input (default Trigger in) (FL2G models only)
	2	IO1	Input / Output Opto-isolated Output (FL2G models only)
	3	IO2	Input / Output / RS232 Transmit (TX)
	4	IO3	Input / Output / RS232 Receive (RX)
	5	GND	Ground Ground for bi-directional IO, VEXT, +3.3V pins (FL2G models only)
	6	GND	Ground Ground for opto-isolated IO pins (FL2G models only)
	7	Vext	Allows the camera to be powered externally. Voltage limit: 8 to 30V, Current limit: 1A
	8	+3.3V	Power external circuitry up to a total of 150mA

To configure the GPIO pins, consult the "General Purpose Input / Output" section of the PGR IEEE-1394 Digital Camera Register Reference.

## 8. Confirm Successful Installation

- Check the Device Manager to confirm that installation was successful (PGRCAM driver install only). Go to the **Start** menu, select **Run** and enter "**devmgmt.msc**".
- To test the camera's image acquisition capabilities, run the FlyCap demo program.

# 2 Troubleshooting

The FlyCapture® User Guide and other technical references can be found in the **Programs > Point Grey Research > PGR FlyCapture > Documentation** directory. Our on-line Knowledge Base ([www.ptgrey.com/support/kb/](http://www.ptgrey.com/support/kb/)) also addresses the following problems:

- Article 21: Troublesome hardware configurations
- Article 88: Vertical bleeding or smearing from a saturated portion of an image
- Article 91: PGR camera not recognized by system and not listed in Device Manager
- Article 93: My laptop's IEEE-1394 port or PCMCIA card doesn't supply power to my camera
- Article 145: Image discontinuities or horizontal tearing of images when displayed on monitor
- Article 171: Performance of 1394 devices may decrease after installing Windows XP SP2
- Article 188: Image data acquired by my camera is corrupt and displayed images are broken
- Article 189: Image capture freezes after a period of successful image capture.

### CONTACTING POINT GREY RESEARCH

#### Email:

For all general questions about Point Grey Research please contact us at [info@ptgrey.com](mailto:info@ptgrey.com). For technical support (existing customers only) contact us at [www.ptgrey.com/support/contact/](http://www.ptgrey.com/support/contact/).

#### Main Office:

**Mailing Address:**  
Point Grey Research, Inc.  
Richmond B.C. Canada  
12051 Riverside Way  
V6W 1K7

**Tel:** +1 (604) 242-9937  
**Toll Free** (N.America only): +1 (866) 765-0827  
**Fax:** +1 (604) 242-9938  
**Email:** [sales@ptgrey.com](mailto:sales@ptgrey.com)

#### Knowledge Base:

Find answers to commonly asked questions in our knowledge base at [www.ptgrey.com/support/kb/](http://www.ptgrey.com/support/kb/).

#### Downloads:

Users can download the latest manuals and software from [www.ptgrey.com/support/downloads/](http://www.ptgrey.com/support/downloads/).