

Getting Started

Grasshopper™ IEEE-1394b Digital Camera



SPECTRAL RESPONSE (QE)

For full sensor datasheets, including spectral response graphs, go to: www.ptgrey.com/support/kb/index.asp?a=4&q=23

STATUS LED

The Grasshopper is equipped with a bi-color LED that can be red, green, or yellow (when both green and red are turned on). If the LED does not turn on at all when the camera is connected to the IEEE-1394b host adapter card, check that the camera is receiving adequate power. Refer to [Knowledge Base Article 93](#) for a list of options to consider when running the camera off a laptop (notebook) computer.

FireWire activity: isochronous or asynchronous transmission of data on the IEEE-1394 bus

Configuration error: Bit [0] of VMODE_ERROR_STATUS register 0x628

Powered down: Power controlled via CAMERA_POWER register 0x610

LED Behaviour	Possible Causes
Maximum red (initial connection)	Initial startup. On until camera is being initialized
Maximum red (during operation)	Condition 1: Bus reset. On for 0.66s. Condition 2: Power failure. On until power-up via CAMERA_POWER 0x610.
Dull red	Configuration error.
Bright red	Configuration error.
Dull green	Camera is idle.
Bright green	FireWire activity. On for 0.5s during activity.
Dull yellow	Powered down.
Bright yellow	Powered down + FireWire activity. Bright for 0.5s during activity.
Red / green flashing	Camera firmware is being updated. Flashes at 5Hz.



SPECIFICATIONS

	GRAS-03K2M/C	GRAS-03S3M	GRAS-14S3M/C	GRAS-14S5M/C	GRAS-20S4M/C	GRAS-50S5M/C
Image Sensor Type	Kodak (K) and Sony (S) progressive scan interline transfer CCD's with square pixels and global shutter					
Image Sensor Model	KAI-0340D 1/3"	ICX414 1/2"	ICX267 1/2"	ICX285 2/3" EXView HAD	ICX274 1/1.8"	ICX625 2/3" Super HAD
Maximum Resolution and Max Frame Rate¹	640x480 at 200 FPS	648x488 at 74 FPS	1384x1032 at 21 FPS	1384x1036 at 15 FPS	1624x1224 at 30 FPS	2448x2048 at 15 FPS
Pixel Size	7.4µm x 7.4µm	9.9µm x 9.9µm	4.65µm x 4.65µm	6.45µm x 6.45µm	4.40µm x 4.40µm	3.45µm x 3.45µm
Analog-to-Digital Converter	Analog Devices 14-bit ADC					
Video Data Output	8, 12, 16 and 24-bit digital data					
Image Data Formats	Y8,Y16 (all models), RGB, YUV411, YUV422, YUV444, 8-bit and 16-bit RAW Bayer data (color models)					
Digital Interface / Transfer Rates	Dual bilingual 9-pin IEEE-1394b for camera control, video data transmission and daisy chaining Transfer Rates: 100, 200, 400, 800 Mbit/s					
Partial Image Modes	pixel binning and region of interest modes via Format_7					
General Purpose I/O Ports	8-pin Hirose HR25 general purpose input/output connector; 4 pins for external trigger, strobe or RS232, 1 pin +3.3V, 1 Vext pin (external power)					
Gain Control	automatic / manual / one-push gain modes, programmable via software, 0dB to 24dB in 0.04dB increments					
Shutter Speed	automatic / manual / one-push modes, programmable via software, 0.02ms to greater than 10s (extended shutter mode)					
Synchronization	via external trigger, software trigger (on same bus only), or free-running					
External Trigger Modes	DCAM v1.31 Trigger Modes 0, 1 (bulb shutter), 3, 14 (overlapped trigger and transfer), and 15 (multi-shot trigger)					
Voltage Requirements	8-30V, via the IEEE-1394b interface or Hirose 8-pin GPIO connector					
Power Consumption (max at 12V)	2.9W	2.9W	3.0W	3.1W	3.4W	3.8W
Dimensions (L x W x H)	44mm x 29mm x 58mm (not including lens holder and GPIO connector)					
Mass	104g (without optics)					
Camera Specification	IIDC 1394-based Digital Camera Specification v1.31, compatible with IEEE-1394b and IEEE-1394a interfaces					
Lens Mount	C-mount					
Emissions Compliance	Complies with CE rules and Part 15 Class A of FCC Rules					
Operating Temperature	0° to 40°C					
Storage Temperature	-30° to 60°C					
Vibration Resistance	10 G (14 Hz to 200 Hz)					

¹ Maximum frame rates and maximum resolutions are achieved using Format 7 custom image modes

STANDARD IMAGE FORMATS

Model	Frames Per Second					
	1.875	3.75	7.5	15	30	60
160x120 YUV444	●●●	●●●	●●●	●●●	●●●	●●●
320x240 YUV422	●●●	●●●	●●●	●●●	●●●	●●●
640x480 YUV411	●●●	●●●	●●●	●●●	●●●	●●●
640x480 YUV422	●●●	●●●	●●●	●●●	●●●	●●●
640x480 RGB	●●●	●●●	●●●	●●●	●●●	●●●
640x480 Y16	●●●●●●	●●●●●●	●●●●●●	●●●●●●	●●●●●●	●●●●●●
640x480 Y8	●●●●●●	●●●●●●	●●●●●●	●●●●●●	●●●●●●	●●●●●●
800x600 YUV422	●●●	●●●	●●●	●●●	●●●	●●●
800x600 RGB	●●●	●●●	●●●	●●●	●●●	●●●
800x600 Y16	●●●●●●	●●●●●●	●●●●●●	●●●●●●	●●●●●●	●●●●●●
800x600 Y8	●●●●●●	●●●●●●	●●●●●●	●●●●●●	●●●●●●	●●●●●●
1024x768 YUV422	●●●	●●●	●●●	●●●	●●●	●●●
1024x768 RGB	●●●	●●●	●●●	●●●	●●●	●●●
1024x768 Y16	●●●●●●	●●●●●●	●●●●●●	●●●●●●	●●●●●●	●●●●●●
1024x768 Y8	●●●●●●	●●●●●●	●●●●●●	●●●●●●	●●●●●●	●●●●●●
1280x960 YUV422	●●●	●●●	●●●	●●●	●●●	●●●
1280x960 RGB	●●●	●●●	●●●	●●●	●●●	●●●
1280x960 Y16	●●●●●●	●●●●●●	●●●●●●	●●●●●●	●●●●●●	●●●●●●
1280x960 Y8	●●●●●●	●●●●●●	●●●●●●	●●●●●●	●●●●●●	●●●●●●
1600x1200 YUV422	●●●	●●●	●●●	●●●	●●●	●●●
1600x1200 RGB	●●●	●●●	●●●	●●●	●●●	●●●
1600x1200 Y16	●●●●●●	●●●●●●	●●●●●●	●●●●●●	●●●●●●	●●●●●●
1600x1200 Y8	●●●●●●	●●●●●●	●●●●●●	●●●●●●	●●●●●●	●●●●●●

NOTE: Full resolution images, maximum frame rates, and raw Bayer output (color cameras) can be achieved using Format 7. Access Format 7 modes using "Custom Image Mode" in FlyCapture.

CAMERA INTERFACE

IEEE-1394b Connector and Cables

The Grasshopper has two standard 9-pin IEEE-1394b connectors that can be used for data transmission, camera control and powering the camera. The maximum 1394b cable length between any 1394 node (e.g. camera to PCI card) is 4.5m, as specified by the IEEE-1394 standard. Use standard, shielded twisted pair copper cables. If the LED does not turn on at all when the camera is connected to the IEEE-1394b host adapter card, check that the camera is receiving adequate power. Refer to [Knowledge Base Article 93](#) for a list of options to consider when running the camera off a laptop.

General Purpose I/O Connector

The Grasshopper has a Hirose HR25 8-pin general purpose input/output (GPIO) female connector on the back of the case (P/N: HR25-7TR-8SA). The development accessory kit includes a one (1) meter long wiring harness equipped with a male connector (P/N: HR25-7TP-8P, Digikey P/N: HR702-ND). Wires are color coded or labelled according to the table below to indicate functionality.

Diagram	Pin	Function	Description
	1	IO0	Input / Output (default Trigger_Src)
	2	IO1	Input / Output
	3	IO2	Input / Output / RS232 Transmit (TX)
	4	IO3	Input / Output / RS232 Receive (RX)
	5,6	GND	
	7	Vext	Allows the camera to be powered externally. Voltage limit: 8 to 30V, Current limit: 1A
	8	+3.3V	Power external circuitry up to a total of 150mA
	To configure the GPIO pins, consult the "General Purpose Input / Output" section of the PGR IEEE-1394 Digital Camera Register Reference.		

Inputs can be configured to accept external trigger signals. **Outputs** can be configured to send an output signal or strobe pulse. Refer to the *Grasshopper Technical Reference* for detailed GPIO electrical characteristics.

1 Installation

1. Recommended System Configuration

OS	CPU	RAM	VIDEO	PORTS
Vista SP1, Win7, Linux Ubuntu 8.04	2.0GHz or equivalent	2 GB	AGP 128mb	IEEE-1394b

- Windows XP Service Pack 1
- 512MB of RAM
- Intel Pentium 4 2.0GHz or compatible processor
- AGP video card with 128MB video memory
- 64-bit PCI or PCI-X slot (32-bit slot required)
- PCI-Express slot
- 1394b PCI card or 1394b PCI-Express card (available in dev kit)
- Microsoft Visual C++ 6.0 (to compile and run example code)

2. Electrostatic Precautions and Camera Care

- Users who have purchased a bare board camera should:



- This product is not intended for use in residential environments.
- Either handle bare handed or use non-chargeable gloves, clothes or material. Also use conductive shoes.
- Install a conductive mat on the floor or working table to prevent the generation of static electricity.



- When handling the camera unit, avoid touching the lenses. To clean the lenses, use a standard camera lens cleaning kit or a clean dry cotton cloth. Do not apply excessive force.
- This device complies with Part 15 of the FCC Rules. Operation is subject to the following two conditions: (1) This device may not cause harmful interference, and (2) this device must accept any interference received, including interference that may cause undesirable operation. This Class A digital apparatus complies with Canadian ICES-003. Cet appareil numérique de la classe B est conforme à la norme NMB-003 du Canada.

- To clean the imaging surface of your CCD, follow the steps outlined in www.ptgrey.com/support/kb/index.asp?a=4&q=66.
- Extended exposure to bright sunlight, rain, dusty environments, etc. may cause problems with the electronics and the optics of the system.
- Avoid excessive shaking, dropping or mishandling of the device.

2 Installation

3. Install the IEEE-1394b PCI or PCIe card

- Turn computer off and place the IEEE-1394b PCI card in an open PCI slot or place the IEEE-1394b PCI-Express card in an open PCI-Express slot.

IEEE-1394b Host Adapter 2 Port PCI card

FirePRO low profile single bus IEEE-1394b PCIe card

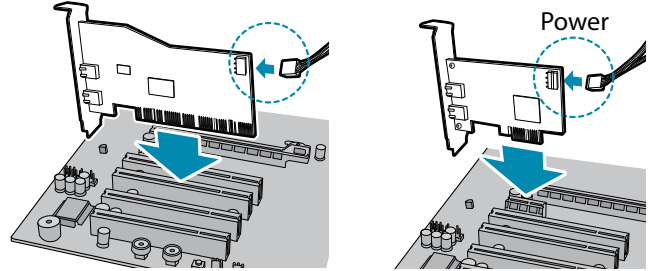

- Connect the 4-pin connector on the card to the PC power supply.
- Turn the computer back on and log into Windows.
- In most cases, the Windows IEEE-1394 drivers will be automatically installed for the card, with no user input required. However, in some cases the **Found New Hardware Wizard** will appear. Follow the prompts given by the Wizard to install the card.
- Open Windows Device Manager by going to the **Control Panel > System > Hardware tab > Device Manager**. Ensure the PCI card is properly installed as an **IEEE 1394 Bus host controller**.

4. Install the FlyCapture® Software and Drivers

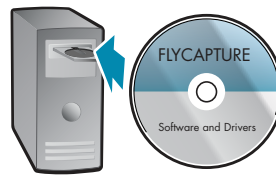

- Insert the FlyCapture software CD-ROM. If the Installation Wizard does not automatically run, browse to your CD-ROM directory and run the **setup.exe** file.

- Follow the installation instructions to install the software.



IMPORTANT NOTE for Windows XP Users

A dialog will appear prompting you to install the **FirePRO** driver. We strongly recommend doing this in order to take full advantage of 1394b 800Mb/s speeds. See this Knowledge Base article for further information: www.ptgrey.com/support/kb/index.asp?a=4&q=171

3 Installation

5. Installing the Tripod Mounting Bracket (optional)

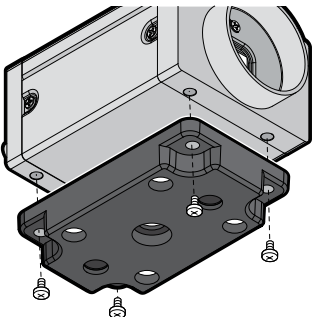

- The ASA and ISO-compliant tripod mounting bracket for the Grasshopper attaches to the camera using the included M2x5 screws.

6. Connect the 1394b PCI Card and Cable to the camera

- Plug the 4.5 meter, 9-pin to 9-pin, IEEE-1394b cable into the 1394b PCI card and the Grasshopper 1394b connector; the cable jack screws can be used for a secure connection.

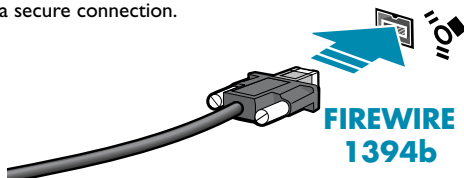

NOTE: The camera relies on the 9-pin 1394b cable to provide power. If using an interface card other than that provided, ensure that adequate power is provided.

- If the Microsoft Windows "**Found New Hardware Wizard**" appears, proceed to Step 7. Otherwise, proceed to Step 8.

7. Install the PGR CAM Driver

- Click "**Install from a list or specific location**" and click "**Next**".
- Select "**Don't search. I will choose the driver to install**" and "**Next**".
- Click "**Have Disk**" and browse to **C:\Program Files\Point Grey Research\PGR FlyCapture\driver**, click "**Open**", then "**OK**".
- Select the camera model. Click "**Next**".
- You will be prompted to continue installation - click "**Continue Anyway**" then "**Finish**" to complete installation.

8. Confirm Successful Installation

- Check the Device Manager to confirm that installation was successful (PGR CAM driver install only). Go to the **Start** menu, select **Run** and enter "**devmgmt.msc**".
- To test the camera's image acquisition capabilities, run the FlyCap demo program. From the **Start** menu, select **All Programs > Point Grey Research > PGR FlyCapture > FlyCap.exe**.

4 Troubleshooting

The FlyCapture® User Guide and other technical references can be found in the **Programs > Point Grey Research > PGR FlyCapture > Documentation** directory. Our on-line Knowledge Base (www.ptgrey.com/support/kb/) also addresses the following problems:

- Article 21: Troublesome hardware configurations
- Article 88: Vertical bleeding or smearing from a saturated portion of an image
- Article 91: PGR camera not recognized by system and not listed in Device Manager
- Article 93: My laptop's IEEE-1394 port or PCMCIA card doesn't supply power to my camera
- Article 145: Image discontinuities or horizontal tearing of images when displayed on monitor
- Article 171: Performance of 1394 devices may decrease after installing Windows XP SP2
- Article 188: Image data acquired by my camera is corrupt and displayed images are broken
- Article 189: Image capture freezes after a period of successful image capture.

CONTACTING POINT GREY RESEARCH

Email:

For all general questions about Point Grey Research please contact us at info@ptgrey.com.

For technical support (existing customers only) contact us at www.ptgrey.com/support/contact/.

Main Office:

Mailing Address:
Point Grey Research, Inc.
Richmond B.C. Canada
12051 Riverside Way
V6W 1K7

Tel: +1 (604) 242-9937
Toll Free (N.America only): +1 (866) 765-0827
Fax: +1 (604) 242-9938
Email: sales@ptgrey.com