

Firefly[®] MV Camera Enclosure



POINT GREY
RESEARCH

- **Protective aluminum enclosure**
- **Multiple mounting options**
- **Ultra-compact 19.5x50x35mm size**
- **Access to GPIO and I394 connectors**

This light and ultra-compact anodized aluminum case for the Firefly MV FFMV-03MT-CS helps minimize the effects of accidental electrostatic discharge on the camera's electrical components, and maximize integration flexibility.

Multiple mounting options on the top and bottom of the case also allow easy integration into larger custom enclosures, while still providing complete access to the camera's status LED, general purpose input/output (GPIO) pins, and IEEE-1394 digital interface. A label cutout on the side of the case allows further customization for OEM's and system integrators.



Firefly[®] MV Aluminum Case
(camera sold separately)

General Specifications

Dimensions	19.5x50x35mm
Mass	35g
Material	6061 aluminum
Mounting Holes	M3x3 tapped (x4), M2x4 tapped (x8)
Color	Black anodized
Compliance	RoHS
Use	Indoor use only

Kit Components

- Firefly MV case (front and back plate)
- M2x4.5 assembly screws (x8)
- Tripod mounting bracket (Point Grey p/n ACC-01-0003)



Easy access to IEEE-1394 and GPIO connectors



Compatible with C-mount lens adapter (sold separately)

Point Grey Part Number

- ACC-01-0010

Point Grey Product Compatibility

- Firefly MV with CS lens mount (FFMV-03MT-CS)
- 5mm C-mount adapter (ACC-01-5004)

Dimensions

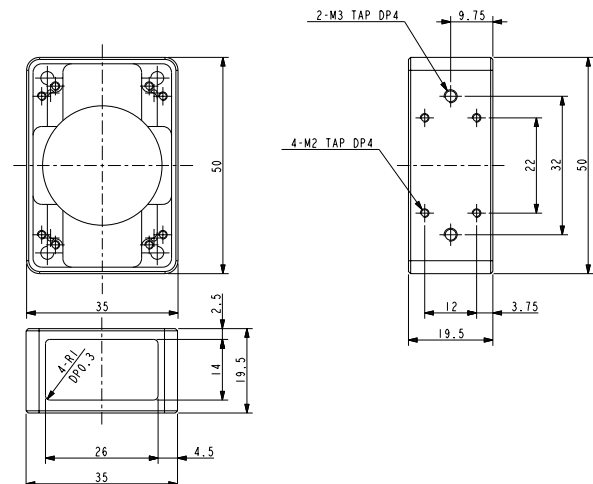

August 2008