

# GRASSHOPPER 2

HIGH-RESOLUTION + COMPACT + VERSATILE



— 44mm —



— 29mm —

— 58mm —



**GiGE**<sup>TM</sup>  
VISION

GEN*i*CAM

 **POINT GREY**

*Innovation in Imaging*

# Grasshopper<sup>®</sup>2

The fully redesigned Grasshopper2 camera series is the next generation version of the high performance Grasshopper and features a GigE Vision digital interface. The Grasshopper2 uses the same form factor as the existing Grasshopper and a selection of the same image sensors, and adds several new features, including enhanced opto-isolated general purpose I/O and improved imaging performance.

- Sony progressive scan CCD image sensors, mono or color
- GigE Vision 1000 Mbit/s interface
- Compact 44 x 29 x 58 mm case with C-mount lens holder
- GigE Vision 1.2 specifications



## Gigabit Ethernet Models

<b>2.0 MP</b>	Sony ICX274 CCD, 1/1.8", 4.4 x 4.4 μm	1624 x 1224 at 29 FPS
<b>5.0 MP</b>	Sony ICX625 CCD, 2/3", 3.45 x 3.45 μm	2448 x 2048 at 15 FPS

SPECIFICATIONS	GS2-GE-20S4M / C	GS2-GE-50S5M / C
<b>Image Sensor Type</b>	Sony progressive scan interline transfer CCD's with square pixels and global shutter	
<b>Image Sensor Model</b>	Sony ICX274 1/1.8"	Sony ICX625 2/3"
<b>Max Res and Max Frame Rate</b>	1624 x 1224 at 29 FPS	2448 x 2048 at 15 FPS
<b>Pixel Size</b>	4.4 x 4.4 μm	3.45 x 3.45 μm
<b>Analog-to-Digital Converter</b>	Analog Devices 14-bit ADC	
<b>Video Data Output</b>	8, 12, 16 and 24-bit digital data	
<b>Image Data Formats</b>	Y8, Y16, Mono8, Mono12, Mono16, Raw16 (all models) RGB, YUV411, YUV422, YUV444, Raw8, Raw12, Raw16 (color models)	
<b>Digital Interface</b>	Gigabit Ethernet 1000 Mbit/s	
<b>Partial Image Modes</b>	2x2 and 4x4 pixel binning and region of interest modes	
<b>General Purpose I/O Ports</b>	8-pin GPIO connector for power; trigger; strobe; PWM, and serial I/O 1 opto-isolated input, 1 opto-isolated output, 2 bi-directional I/O pins	
<b>Gain Control</b>	automatic / manual / one-push gain modes, programmable via software, -2.6dB to 24dB in 0.04dB increments	
<b>Shutter Speed</b>	automatic / manual / one-push modes, programmable via software, 0.03ms to 32s	
<b>Synchronization</b>	via external trigger or software trigger	
<b>External Trigger Modes</b>	External hardware or software trigger Multiple exposure, bulb shutter, multi-shot, and overlapped trigger modes	
<b>Power / Voltage</b>	Power: < 4.7 W Voltage: 12-24V	
<b>Dimensions (W x H x L)</b>	44mm x 29mm x 58mm (not including lens holder and GPIO connector)	
<b>Mass</b>	86 grams (without optics)	
<b>Memory Storage</b>	32MB frame buffer, 512 KB non-volatile data flash	
<b>Memory Channels</b>	2 memory channels for custom camera settings	
<b>Camera Specification</b>	GigE Vision™ Specification v1.2	
<b>Lens Mount</b>	C-mount	
<b>Emissions Compliance</b>	CE, FCC, RoHS	
<b>Operating Temperature</b>	0° to 45°C	
<b>Storage Temperature</b>	-30° to 60°C	
<b>Vibration Resistance</b>	10 G (14 Hz to 200 Hz)	
<b>Status Monitoring</b>	Bi-color LED that can be red, green, or yellow	

<sup>1</sup> Maximum frame rate at full resolution achieved using Format 7



# Grasshopper<sup>®</sup> 2 Specifications

## GigE Benefits

The 1000Mb/s Gigabit Ethernet bus provides enough bandwidth to transmit uncompressed 5MP images at 15FPS over distances up to 100m. System costs are reduced with low-cost frame grabbers and by eliminating the need for cable repeaters. Scalability also reduces future costs as GigE Vision continues development for faster bandwidths.

## Opto-Isolated GPIO

Opto-isolated GPIO protects the camera from noise on the ground pin generated by external devices as well as power issues caused by malfunctioning devices attached to the camera.

## Secure Connector

Screw holes on each side of the camera's GigE connector enable secure connection to the camera, guaranteeing a reliable connection, and reducing stress on internal electronics caused by cable movement.

## Industry Standard Design

Every mechanical component of the Grasshopper2 camera is designed to maximize usability, including the compact aluminum case, C-mount lens holder and ASA/ISO-compliant tripod mounting bracket, status LED and removable glass/IR filter system.

## Triggering

Hardware and software triggering for synchronizing multiple cameras or coordinating with external devices. Supported modes include standard, bulb shutter, skip frames, multiple exposure (preset and pulse width), overlapped exposure/readout and multi-shot

## Dimensional Drawings (in mm)

CAD models available at [www.ptgrey.com/support/downloads](http://www.ptgrey.com/support/downloads).

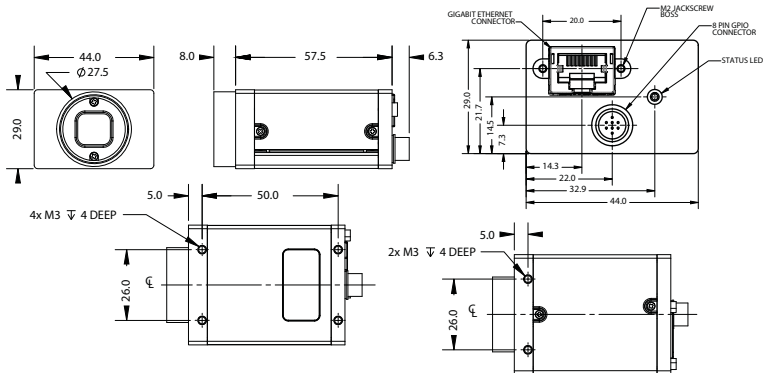

## Frame Buffer/Image Retransmit

The camera is equipped with a 32MB frame buffer that can be used to store multiple images for transmission, or retransmission, at a later time. This is useful in situations where the available GigE bandwidth must be maximized between multiple cameras, or where an image must be sent again.

## Updatable FPGA

The field-programmable gate array chip controls all camera functionality, including on-camera color processing, pixel binning, user memory channels and more. It can also be updated with new firmware in the field.

## Software

The FlyCapture<sup>®</sup> SDK is compatible with Microsoft<sup>®</sup> Windows<sup>®</sup> and Linux Ubuntu and a full software API library, demo programs and C/C++/C# example source code. It also includes the Point Grey filter driver, which provides enhanced data communication between the GigE bus and the CPU and the GigE Configurator tool for configuring IP addressing.

## Accessories

Tripod adapter with every camera. All the accessories you need to get up and running, such as interface cards, cables, and power adapters are available from Point Grey.

