

FIREFLY® MV SPECIFICATIONS

SPECIFICATION	FFMV-03MTM/C (BW or Color)
Image Sensor Type	1/3" progressive scan CMOS
Shutter Type	Global shutter using Micron TrueSNAP™ technology
Image Sensor Model	Micron MT9V022
Maximum Resolution	752 (H) x 480 (V)
Pixel Size	6.0 µm x 6.0 µm
Analog-to-Digital Converter	On-chip 10-bit ADC
Video Data Output	8 and 16-bit digital data
Image Data Formats	Y8, Y16 (monochrome), 8-bit and 16-bit raw Bayer data (color models)
Digital Interface	6-pin IEEE 1394a for camera control, video data, power
Transfer Rates	400 Mb/s
Maximum Frame Rate	752x480 at 61 FPS • 320x240 at 112 FPS (region of interest) 320x240 at 122 FPS (2 x 2 pixel binning)
Partial Image Modes	pixel binning and region of interest modes via Format_7
General Purpose I/O Ports	7-pin JST GPIO connector, 4 pins for trigger and strobe, 1 pin +3.3 V, 1 Vext pin for external power
Gain Control	automatic / manual, 0 dB to 12 dB
Shutter Speed	automatic / manual, 0.12 ms to 512 ms
Gamma	0 to 1 (enables 12-bit to 10-bit companding)
Synchronization	via external trigger, software trigger, or free-running!
External Trigger Modes	I2DC v1.31 Trigger Modes 0 and 3
Power Requirements	8 to 30 V via IEEE-1394, less than one (1) Watt
Dimensions (L x W x H)	24.4 x 44 x 34 mm
Mass	37 g (including tripod adapter)
Camera Specifications	I2DC 1394-based Digital Camera Specification v1.31
Memory Storage	three memory channels for user configurable power-up settings
Lens Mount	CS-mount (5mm C-mount adapter included) • M12 microlense mount ²
Compliance	CE, FCC Class B, RoHS
Operating Temperature	0° to 45°C
Storage Temperature	-30° to 60°C
Configuration Options	board-level ² • microlens ² • mini 1394 connector ² • metal case

¹ Using standard non-Format_7 video formats and modes operating at 30 FPS and 60 FPS only. ² For qualified OEMs

IMAGE ACQUISITION

Global Shutter	Photodiode pixels with simultaneous integration and readout
Near-IR Performance	Enhanced performance provides NIR QE greater than 35%
Auto Exposure Control	Ensures optimal auto settings of shutter and gain for each image
Fast Frame Rates	Faster standard frame rates up to 60 FPS
Partial Image Modes	Format_7 modes for fast frame rates and higher signal-to-noise
Multiple Trigger Modes	Standard external trigger mode, skip frames mode
Gain and Brightness	Adjust gain and black clamp via a 10-bit A/D converter

IMAGE PROCESSING

ADC On-Chip	10-bit linear or 12-bit to 10-bit companding mode via Gamma
Image Flip	Horizontal image flipping (mirror image)
Embedded Image Info	Pixels contain image timestamp (1394 cycle time)

CAMERA AND DEVICE CONTROL

Memory Channels	Non-volatile storage of camera default power-up settings
Strobe Output	Strobe output with configurable delay and duration
Absolute Value Controls	Shutter and gain reported in real-world units (seconds and dB)
Broadcast Properties	Camera responds to broadcast register writes on the same bus
Camera Upgrades	Firmware upgradeable in field via IEEE-1394 interface.

STATUS LED

Steady on	Receiving power and successful camera initialization
Steady on and very bright	Acquiring / transmitting images
Flashing bright, then brighter	Camera registers being accessed (no image acquisition)
Steady or slow flashing on and off	Camera firmware updated (requires power cycle), or possible camera problem

CAMERA INTERFACE

IEEE-1394 Connector

The Firefly® MV has a standard 6-pin IEEE-1394 connector that is used for data transmission, camera control and powering the camera.

Cables

The maximum 1394 cable length between any 1394 node (e.g. camera to PCI card, card to hub, etc.) is 4.5m, as specified by the IEEE-1394 standard. Use standard, shielded twisted pair copper cables.

General Purpose I/O Connector

The Firefly MV has a 7-pin GPIO connector on the back of the board. The connector is made by JST (Mfg P/N: BM07B-SRSS-TB). The Development Kit contents include a pre-wired female connector; refer to the diagram below for wire color-coding. Additional female connectors (Mfg P/N: SHR-07V-S-B) can be purchased from Digikay (P/N: 455-1382-ND).

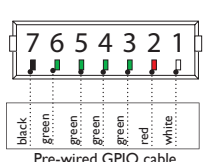
Diagram	Pin	Function	Description
 <p>Pre-wired GPIO cable</p>	1	Vext	Power camera externally
	2	+3.3V	Power external circuitry up to a total of 150mA
	3	IO0	Input / Output (Default Trigger_Src)
	4	IO1	Input / Output
	5	IO2	Input / Output / RS232 Transmit (TX)
	6	IO3	Input / Output / RS232 Receive (RX)
	7	GND	

To configure the GPIO pins, consult the "General Purpose Input / Output" section of the PGR IEEE-1394 Digital Camera Register Reference.

The Firefly MV GPIO pins are TTL 3.3V pins. **Inputs** can be configured to accept external trigger signals. When configured as inputs, the pins are internally pulled high using weak pull-up resistors to allow easy triggering of the camera by simply shorting the pin to ground (GND). Inputs can also be directly driven from a 3.3V or 5V logic output. The inputs are protected from both over and under voltage. It is recommended, however, that they only be connected to 5V or 3.3V digital logic signals. **Outputs** can be configured to send an output signal or strobe pulse. When configured as outputs, each line can sink 10mA of current.

STANDARD IMAGE FORMATS

Mode Description	Frames Per Second					
	1.875	3.75	7.5	15	30*	60*
640x480 Y8 (8bpp)			•	•	•	•
640x480 Y16 (16bpp)			•	•	•	•

*Black and white output only. Color data is removed due to pixel binning.

PARTIAL IMAGE FORMATS (FORMAT_7)

Mode	Pixel Format	Size	FPS	Description
0	Mono8 (8bpp)	752x480	63	Region of interest (ROI)
0	Mono8 (8bpp)	320x240	125	Region of interest (ROI)
0	Mono8 (8bpp)	160x120	210	Region of interest (ROI)
0	Mono8 (8bpp)	320x240	135	2x2 pixel binning
1	Mono8 (8bpp)	640x240	135	1x2 pixel binning

Getting Started

Firefly® MV IEEE-1394a Digital Camera

The following items are included with your Firefly MV Development Accessory Kit

- 2 meter, 6-pin to 6-pin, ultra-thin IEEE-1394 cable
- IEEE-1394 OHCI PCI Host Adapter 3 port-400 Mbps card
- Male GPIO connector pre-wired for quick and easy access
- FlyCapture® SDK (C/C++ API and device drivers) CD



July 2009

TECHNICAL DRAWINGS

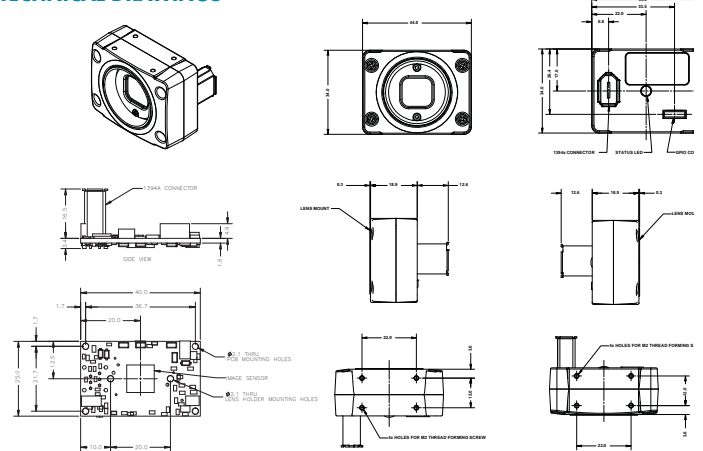

SPECTRAL RESPONSE (QE)

FFMV-03MT / FMVU-03MT

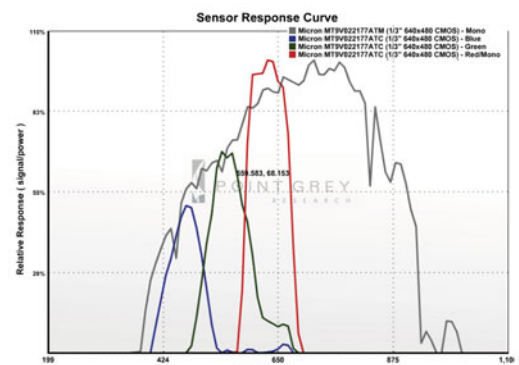

12-BIT TO 10-BIT COMPANDING

A gamma value of 0 yields a linear response; a value of 1 puts the camera into 12-bit to 10-bit mode. This mode allows higher ADC resolution (12 bits) for low-level signals (shadow details) and lower ADC resolution (9 bits) for high-level signals (highlight details).

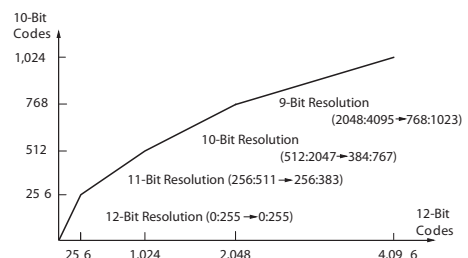

1 Installation

1. Recommended System Configuration

OS	CPU	RAM	VIDEO	PORTS
Windows XP SP1	2.0GHz or equivalent	512mb	AGP 128mb	IEEE-1394a

- Windows XP Service Pack 1
- 512MB of RAM
- Intel Pentium 4 2.0GHz or compatible processor
- AGP video card with 128MB video memory
- 32-bit PCI slot for IEEE-1394 card
- Microsoft Visual C++ 6.0 (to compile and run example code)

2. Electrostatic Precautions and Camera Care

- Users who have purchased a bare board camera should:



- Either handle bare handed or use non-chargeable gloves, clothes or material. Also use conductive shoes.
- Install a conductive mat on the floor or working table to prevent the generation of static electricity.



- When handling the camera unit, avoid touching the lenses. To clean the lenses, use a standard camera lens cleaning kit or a clean dry cotton cloth. Do not apply excessive force.

- To clean the imaging surface of your CCD, follow the steps outlined in www.ptgrey.com/support/kb/index.asp?a=4&q=66.
- Extended exposure to bright sunlight, rain, dusty environments, etc. may cause problems with the electronics and the optics of the system.
- Avoid excessive shaking, dropping or mishandling of the device.

2 Installation

3. Install the IEEE-1394 PCI card

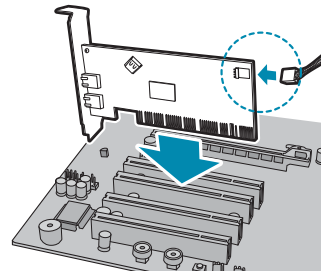

- Turn computer off and place the IEEE-1394b PCI card in an open PCI slot.
- Connect the 4-pin connector on the card to the PC power supply.

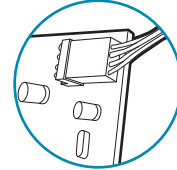

- Turn the computer back on and log into Windows.
- In most cases, the Windows IEEE-1394 drivers will be automatically installed for the card, with no user input required. However, in some cases the **Found New Hardware Wizard** will appear. Follow the prompts given by the Wizard to install the card.
- Open Windows Device Manager by going to the **Control Panel > System > Hardware tab > Device Manager**. Ensure the PCI card is properly installed as an **IEEE 1394 Bus host controller**.

4. Install the FlyCapture® Software and Drivers

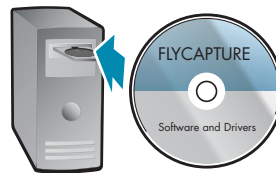

- Insert the FlyCapture software CD-ROM. If the Installation Wizard does not automatically run, browse to your CD-ROM directory and run the **setup.exe** file.

- Follow the installation instructions to install the software.
- A dialog will appear asking if you want to downgrade your Windows XP drivers. If you have installed Service Pack 2, we encourage users to do this. See this Knowledge Base article for further information: www.ptgrey.com/support/kb/index.asp?a=4&q=171

3 Installation

5. Installing the Tripod Mounting Bracket (optional)

- The mounting bracket for the *Firefly® MV* attaches to the camera using the included M2 screws.

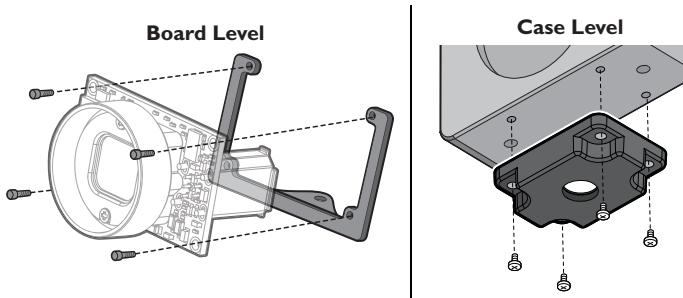

6. Connect the 1394 PCI Card and Cable to the camera

- Plug the 4.5 meter, 6-pin to 6-pin, IEEE-1394 cable into the 1394 PCI card and the *Firefly MV* 1394 Connector.

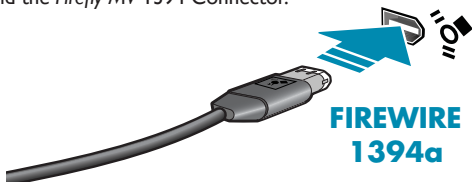

NOTE: The camera relies on the 6-pin 1394 cable to provide power. If using an interface card other than that provided, ensure that adequate power is provided.

- If the Microsoft Windows "**Found New Hardware Wizard**" appears, proceed to Step 7. Otherwise, proceed to Step 8.

7. Install the PGR CAM Driver

- Click "**Install from a list or specific location**" and click "**Next**".
- Select "**Don't search. I will choose the driver to install**" and "**Next**".
- Click "**Have Disk**" and browse to **C:\Program Files\Point Grey Research\PGR FlyCapture\driver**, click "**Open**", then "**OK**".
- Select the camera model (e.g. PGR Dragonfly2 DR2-COL). Click "**Next**".
- You will be prompted to continue installation - click "**Continue Anyway**" then "**Finish**" to complete installation.

4 Troubleshooting

The FlyCapture® User Guide and other technical references can be found in the **Programs > Point Grey Research > PGR FlyCapture > Documentation** directory. Our on-line Knowledge Base (www.ptgrey.com/support/kb/) also addresses the following problems:

- Article 21: Troublesome hardware configurations
- Article 88: Vertical bleeding or smearing from a saturated portion of an image
- Article 91: PGR camera not recognized by system and not listed in Device Manager
- Article 93: My laptop's IEEE-1394 port or PCMCIA card doesn't supply power to my camera
- Article 145: Image discontinuities or horizontal tearing of images when displayed on monitor
- Article 171: Performance of 1394 devices may decrease after installing Windows XP SP2
- Article 188: Image data acquired by my camera is corrupt and displayed images are broken
- Article 189: Image capture freezes after a period of successful image capture.

CONTACTING POINT GREY RESEARCH

Email:

For all general questions about Point Grey Research please contact us at info@ptgrey.com.
For technical support (existing customers only) contact us at www.ptgrey.com/support/contact/.

Main Office:

Mailing Address:
Point Grey Research, Inc.
Richmond B.C. Canada
12051 Riverside Way
V6W 1K7

Tel: +1 (604) 242-9937
Toll Free (N.America only): +1 (866) 765-0827
Fax: +1 (604) 242-9938
Email: sales@ptgrey.com

Knowledge Base:

Find answers to commonly asked questions in our knowledge base at www.ptgrey.com/support/kb/.

Downloads:

Users can download the latest manuals and software from www.ptgrey.com/support/downloads/.

8. Confirm Successful Installation

- Check the Device Manager to confirm that installation was successful. Go to the **Start** menu, select **Run** and enter "**devmgmt.msc**". Verify the camera is listed under "Point Grey Research Devices".
- To test the camera's image acquisition capabilities, run the FlyCap demo program. From the **Start** menu, select **All Programs > Point Grey Research > PGR FlyCapture > FlyCap.exe**.