

GETTING STARTED Grasshopper[®]2

GigE Digital Camera

1 PREPARATION

1. Recommended System Configuration

OS	CPU	RAM	VIDEO	PORTS
Vista or Windows 7	Intel Core 2 Duo	2 GB	PCI Express 128mb	GigE

- Windows Vista or Windows 7
- 2 GB of RAM
- Intel Core 2 Duo or comparable processor
- NVIDIA GeForce6 or later video card with 128MB RAM or more
- Intel® PRO/1000 Gigabit Ethernet Network Adapter PCI Express
- Microsoft Visual Studio 2005 SP1 and SP1 Update for Vista (to compile and run example code)

2. Electrostatic Precautions and Camera Care

- Users who have purchased a bare board camera should:



- This product is not intended for use in residential environments.
- Either handle bare handed or use non-chargeable gloves, clothes or material. Also use conductive shoes.
- Install a conductive mat on the floor or working table to prevent the generation of static electricity.



- When handling the camera unit, avoid touching the lenses. To clean the lenses, use a standard camera lens cleaning kit or a clean dry cotton cloth. Do not apply excessive force.
- This device complies with Part 15 of the FCC Rules. Operation is subject to the following two conditions: (1) This device may not cause harmful interference, and (2) this device must accept any interference received, including interference that may cause undesirable operation. This Class A digital apparatus complies with Canadian ICES-003. Cet appareil numérique de la classe B est conforme à la norme NMB-003 du Canada.

- To clean the imaging surface of your CCD, follow the steps outlined in www.ptgrey.com/support/kb/index.asp?a=4&q=66.
- Extended exposure to bright sunlight, rain, dusty environments, etc. may cause problems with the electronics and the optics of the system.
- Avoid excessive shaking, dropping or mishandling of the device.

2 INSTALLATION

1. Make sure your GigE Network Interface Card is installed according to manufacturer instructions. A 1000 Mbps GigE network interface card (NIC) is required. For optimal video streaming and camera control performance, we recommend a PCI Express (PCIe) interface equipped with an Intel PRO 1000 chipset. Point Grey sells a PCIe card for this purpose (Part No. ACC-01-I100). To purchase, visit <http://www.ptgrey.com/products/accessories/index.asp>.

2. Installing the Tripod Mounting Bracket (optional)

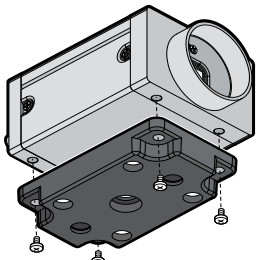

- The ASA and ISO-compliant tripod mounting bracket attaches to the camera using the included M2x5 screws. The bracket is included at no extra charge with every Point Grey Grasshopper2.

3. Connect a Gigabit Ethernet Network Card and Cable to Camera

- Plug a GigE-compatible Cat5, Cat5e or Cat6 cable into the GigE network interface card and the Grasshopper2. If equipped, the cable jack screws can be used for a secure connection. Cables up to 100 meters can be used.

Point Grey sells a 5-meter high-flex Category 5e cable (Part No. ACC-01-2100). This cable is ideal for GigE Vision systems requiring reliable, high performance flex life and signal transmission. To purchase, visit <http://www.ptgrey.com/products/accessories/index.asp>.

4. Supply Power to the Camera

- Connect a 12-24 V DC power supply to the camera's GPIO port. The power supply wiring harness must be compatible with a Hirose HR25 8-pin female GPIO connector. Point Grey sells a 12 V wall-mount power supply for connecting to the camera (Part No. ACC-01-9006). To purchase, visit <http://www.ptgrey.com/products/accessories/index.asp>.

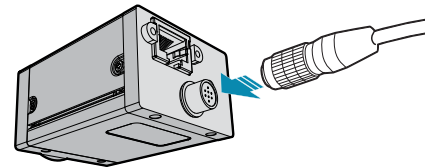

5. Register for a Customer Downloads Account and Install the FlyCapture[®] Software and Drivers

- Go to the Point Grey downloads page <http://www.ptgrey.com/support/downloads/index.asp>
 - **New customers:** Under Register (New Users), complete the form, then click **Submit**. After you submit your registration, you will receive an e-mail with further instructions on how to activate your account.
 - **Existing customers:** login under **Login with an Existing Account**. You will be taken to the product Downloads page. Scroll to the bottom and complete the form under **Add a new purchased product**.
- After activating your account, login to the Point Grey [downloads page](http://www.ptgrey.com/support/downloads/index.asp) (<http://www.ptgrey.com/support/downloads/index.asp>). After login, you will be taken to the downloads page for the products to which you have access. Expand **Software and Drivers for Imaging Products** for your operating system. Under FlyCapture v2x, click the 32- or 64-bit **Download** link to begin the download and installation.
- After the download is complete, the FlyCapture setup wizard begins. Follow the steps in each setup dialog. In the **Interface Driver Selection** dialog, select the **I will use GigE cameras**. This selection ensures the Point Grey Image Filter driver is installed and enabled. The Image Filter Driver operates as a network service between GigE Vision cameras and the Microsoft built-in UDP stack to filter out GigE vision stream protocol (GVSP) packets. (cont'n on next page...)

3 TROUBLESHOOTING

Use of the filter driver is recommended, as it can reduce CPU load and improve image streaming performance. Alternatively, Point Grey GigE Vision cameras can communicate directly with the Microsoft UDP stack. GigE Vision cameras operating on Linux systems communicate directly with native Ubuntu drivers. To uninstall or reconfigure the Image Filter Driver at any time after setup is complete, consult the FlyCapture SDK Help.

Note: For more information about accessing customer downloads, see [Knowledge Base Article 35](http://www.ptgrey.com/support/kb/index.asp?a=4&q=35) (<http://www.ptgrey.com/support/kb/index.asp?a=4&q=35>).

6. Configure IP Settings

After installation completes, the Point Grey GigE Configurator opens. This tool allows you to configure the IP settings of the camera and network card.

Note: If the GigE Configurator does not open automatically, open the tool manually from: **Start -> Point Grey Research -> FlyCapture2 -> Utilities -> GigE Configurator**. If prompted to enable GigE enumeration, select **Yes**.

- In the left pane, select the Local Area Connection corresponding to the GigE network interface card (NIC) to which the camera is connected.
- In the right pane, review maximum transmission unit (MTU). If not 9000, enable jumbo frames on the NIC by clicking **Open Network Connections**. (While most GigE NICs support 9000-byte jumbo frames, this feature is often disabled by default.)
- In the left pane, select your GigE Vision camera. (Note: there may be a delay of several seconds before the camera is detected by the GigE Configurator on startup)
- Under 'Current IP Configuration,' review the IP address. (By default, a dynamic IP address is assigned to the camera according to the DHCP protocol. If DHCP addressing fails, a link-local address is assigned. If necessary, change the IP address of the camera to be on the same subnet as the NIC. If the subnets do not match, the camera is marked 'BAD' on the left pane.
- Under 'Packet Size Discovery,' click **Discover Maximum Packet Size** and note the value.

Note: For more information about using the GigE Configurator, see the online Help included with the tool.

7. Configure Packet Size and Confirm Successful Installation

- Run the FlyCap demo program
Start -> Point Grey Research -> FlyCapture2 -> FlyCap2
- In the camera selection dialog, select the GigE camera that was installed, and click **Configure Selected**.
- In the Camera Control dialog, click **Custom Video Modes** By default, **Packet Size** is set to 1400 bytes. We recommend increasing this value to the size noted in the previous step, as maximizing packet size reduces processing overhead. For more information about packet size, see your camera's technical reference manual.

The FlyCap application is a generic, easy-to-use streaming image viewer included with the FlyCapture SDK that can be used to configure GigE network parameters and test many of the capabilities of your camera. It allows you to view a live video stream from the camera, save individual images, adjust video formats, frame rates, properties and settings of the camera, and access camera registers directly.

Note: For more information about using the FlyCap demo program, see the online Help included with the tool.

The FlyCapture® User Guide and other technical references can be found in the **Programs > Point Grey Research > PGR FlyCapture > Documentation** directory. Our on-line Knowledge Base (www.ptgrey.com/support/kb/) also addresses the following problems:

- Article 88: Vertical bleeding or smearing from a saturated portion of an image
- Article 145: Image discontinuities or horizontal tearing of images when displayed on monitor
- Article 350: Transitioning from the Grasshopper to the Grasshopper2

STATUS LED

The Grasshopper2 is equipped with a bi-color LED that can be red, green, or yellow (when both green and red are turned on). If the LED does not turn on at all when the camera is connected to the GigE host adapter card, check that the camera is receiving adequate power.

LED Behaviour	Description
Off	Not receiving power
Green flashing slowly, low intensity	Camera is receiving power, no IP connection is established or establishing connection with camera control software
Green flashing quickly, low intensity	Establishing IP connection
Steady green, high intensity	Streaming images
Red flashing quickly	Firmware update in progress
Red flashing slowly	General error - contact technical support

TECHNICAL DRAWINGS

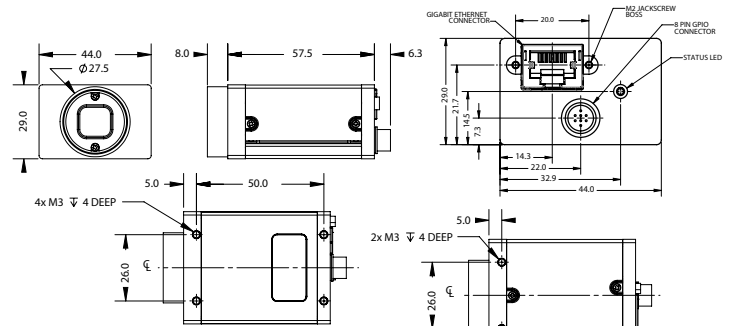

CAMERA INTERFACE

GigE Connector

The 8-pin Halo RJ-45 Ethernet jack is equipped with two M2 screwholes for secure connection. Pin assignments conform to the Ethernet standard. For more information about the orange and green status LEDs on each side of the connector, refer to your camera's technical reference manual.

General Purpose I/O Connector

The Grasshopper2 has a Hirose HR25 8-pin general purpose input/output (GPIO) female connector on the back of the case (P/N: HR25-7TR-8SA).

Diagram	Pin	Function	Description
	1	IO0	Opto-isolated Input (default Trigger in)
	2	IO1	Opto-isolated Output
	3	IO2	Input / Output / RS232 Transmit (TX)
	4	IO3	Input / Output / RS232 Receive (RX)
	5	GND	Ground for bi-directional IO, V _{EXT} , +3.3V pins
	6	GND	Ground for opto-isolated IO pins
	7	V _{EXT}	Allows the camera to be powered externally
	8	+3.3V	Power external circuitry up to a total of 150mA

To configure the GPIO pins, consult section 3.4 "General Purpose Input / Output" of the Grasshopper2 Technical Reference Manual

Inputs can be configured to accept external trigger signals. **Outputs** can be configured to send an output signal or strobe pulse. Refer to the *Grasshopper2 Technical Reference* for detailed GPIO electrical characteristics.

CONTACTING POINT GREY RESEARCH

For all general questions about please contact us at info@ptgrey.com. For technical support (existing customers only) contact us at www.ptgrey.com/support/contact/.

Main Office:

Mailing Address:
Point Grey Research, Inc.
Richmond B.C. Canada
12051 Riverside Way
V6W 1K7

Tel: +1 (604) 242-9937

Toll Free (N.America only): +1 (866) 765-0827

Fax: +1 (604) 242-9938

Email: sales@ptgrey.com