

I Pre-Installation

I. Recommended System Configuration

OS	CPU	RAM	VIDEO	PORTS
Vista SPI, Win7, Linux Ubuntu 8.04	2.0GHz or equivalent	2 GB	AGP 128mb	IEEE-1394b

- Vista SPI, Windows 7, or Linux Ubuntu 8.04
- 2GB of RAM
- Intel Pentium 4 2.0GHz or compatible processor
- AGP video card with 128MB video memory
- 64-bit PCI or PCI-X slot (32-bit slot required)
- PCI-Express slot
- 1394b PCI card or 1394b PCI-Express card (available in dev kit)
- Microsoft Visual Studio 2005 SPI (to compile and run example code)

2. Electrostatic Precautions and Camera Care

- Users who have purchased a bare board camera should:



- This product is not intended for use in residential environments.
- Either handle bare handed or use non-chargeable gloves, clothes or material. Also use conductive shoes.
- Install a conductive mat on the floor or working table to prevent the generation of static electricity.



- When handling the camera unit, avoid touching the lenses. To clean the lenses, use a standard camera lens cleaning kit or a clean dry cotton cloth. Do not apply excessive force.
- This device complies with Part 15 of the FCC Rules. Operation is subject to the following two conditions: (1) This device may not cause harmful interference, and (2) this device must accept any interference received, including interference that may cause undesirable operation. This Class A digital apparatus complies with Canadian ICES-003. Cet appareil numérique de la classe B est conforme à la norme NMB-003 du Canada.

- To clean the imaging surface of your CCD, follow the steps outlined in www.ptgrey.com/support/kb/index.asp?a=4&q=66.
- Extended exposure to bright sunlight, rain, dusty environments, etc. may cause problems with the electronics and the optics of the system.
- Avoid excessive shaking, dropping or mishandling of the device.

2 Installation

3. Install the IEEE-1394b PCI or PCIe card

- Turn computer off and place the IEEE-1394b PCI card in an open PCI slot or place the IEEE-1394b PCI-Express card in an open PCI-Express slot.

IEEE-1394b Host Adapter 2 Port PCI card

FirePRO low profile single bus IEEE-1394b PCIe card

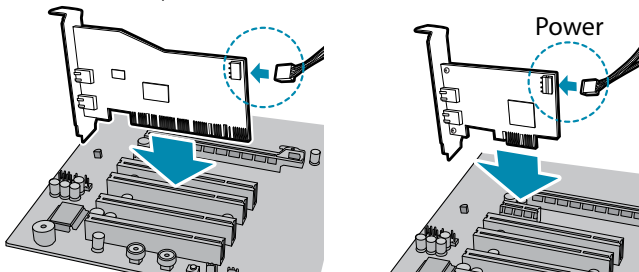

- Connect the 4-pin connector on the card to the PC power supply.
- Turn the computer back on and log into Windows.
- In most cases, the Windows IEEE-1394 drivers will be automatically installed for the card, with no user input required. However, in some cases the **Found New Hardware Wizard** will appear. Follow the prompts given by the Wizard to install the card.
- Open Windows Device Manager by going to the **Control Panel > System > Hardware tab > Device Manager**. Ensure the PCI card is properly installed as an **IEEE 1394 Bus host controller**.

4. Install the FlyCapture® Software and Drivers

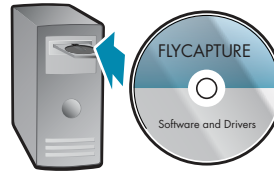

- Follow the installation instructions to install the software.



IMPORTANT NOTE for Windows XP Users

A dialog will appear prompting you to install the **FirePRO** driver. We strongly recommend doing this in order to take full advantage of 1394b 800Mb/s speeds. See this Knowledge Base article for further information: www.ptgrey.com/support/kb/index.asp?a=4&q=171

5. Installing the Tripod Mounting Bracket (optional)

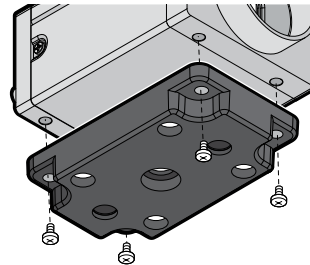

- The ASA and ISO-compliant tripod mounting bracket for the Grasshopper attaches to the camera using the included M2x5 screws.

6. Install a Lens

- Unscrew the dust cap from the c-mount lens holder to install a lens. The Grasshopper2 lens mount is compatible with C-mount lenses. A selection of lenses is available for purchase from Point Grey. For more information go to <http://www.ptgrey.com/products/accessories/index.asp?type=optics>. For further information about selecting a lens, see Knowledge Base article 345 (<http://www.ptgrey.com/support/kb/index.asp?a=4&q=345>).

7. Connect the 1394b PCI Card and Cable to the camera

- Plug the 4.5 meter, 9-pin to 9-pin, IEEE-1394b cable into the 1394b PCI card and the Grasshopper 1394b connector; the cable jack screws can be used for a secure connection.

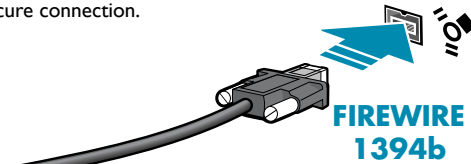

NOTE: The Grasshopper has two standard 9-pin IEEE-1394b connectors that can be used for data transmission, camera control and powering the camera. The maximum 1394b cable length between any 1394 node (e.g. camera to PCI card) is 4.5m, as specified by the IEEE-1394 standard. Use standard, shielded twisted pair copper cables. If the LED does not turn on at all when the camera is connected to the IEEE-1394b host adapter card, check that the camera is receiving adequate power. Refer to [Knowledge Base Article 93](#) for a list of options to consider when running the camera off a laptop.

- If the Microsoft Windows **"Found New Hardware Wizard"** appears, proceed to Step 7. Otherwise, proceed to Step 8.

8. Install the PGR CAM Driver

- Click **"Install from a list or specific location"** and click **"Next"**.
- Select **"Don't search. I will choose the driver to install"** and **"Next"**.
- Click **"Have Disk"** and browse to **C:\Program Files\Point Grey Research\PGR FlyCapture\driver**, click **"Open"**, then **"OK"**.
- Select the camera model. Click **"Next"**.
- You will be prompted to continue installation - click **"Continue Anyway"** then **"Finish"** to complete installation.

9. Confirm Successful Installation

- Check the Device Manager to confirm that installation was successful (PGR CAM driver install only). Go to the **Start** menu, select **Run** and enter **"devmgmt.msc"**.
- To test the camera's image acquisition capabilities, run the FlyCap demo program. From the **Start** menu, select **All Programs > Point Grey Research > PGR FlyCapture > FlyCap.exe**.

3 Troubleshooting

The FlyCapture® User Guide and other technical references can be found in the **Programs > Point Grey Research > PGR FlyCapture > Documentation** directory. Our on-line Knowledge Base (www.ptgrey.com/support/kb/) also addresses the following problems:

- Article 21: Troublesome hardware configurations
- Article 88: Vertical bleeding or smearing from a saturated portion of an image
- Article 91: PGR camera not recognized by system and not listed in Device Manager
- Article 93: My laptop's IEEE-1394 port or PCMCIA card doesn't supply power to my camera
- Article 145: Image discontinuities or horizontal tearing of images when displayed on monitor
- Article 171: Performance of 1394 devices may decrease after installing Windows XP SP2
- Article 188: Image data acquired by my camera is corrupt and displayed images are broken
- Article 189: Image capture freezes after a period of successful image capture.

CONTACTING POINT GREY RESEARCH

Email:

For all general questions about Point Grey Research please contact us at info@ptgrey.com.

For technical support (existing customers only) contact us at www.ptgrey.com/support/contact/.

Main Office:

Mailing Address:
Point Grey Research, Inc.
Richmond B.C. Canada
12051 Riverside Way
V6W 1K7

Tel: +1 (604) 242-9937
Toll Free (N.America only): +1 (866) 765-0827
Fax: +1 (604) 242-9938
Email: sales@ptgrey.com

STATUS LED

Off	Not receiving power
Steady on	Receiving power and successful camera initialization
Steady on and very bright	Acquiring / transmitting images
Flashing bright, then brighter	Camera registers being accessed (no image acquisition)
Steady flashing on and off	Indicates possible camera problem
Slow flashing on and off	Indicates possible camera problem

TECHNICAL DRAWINGS

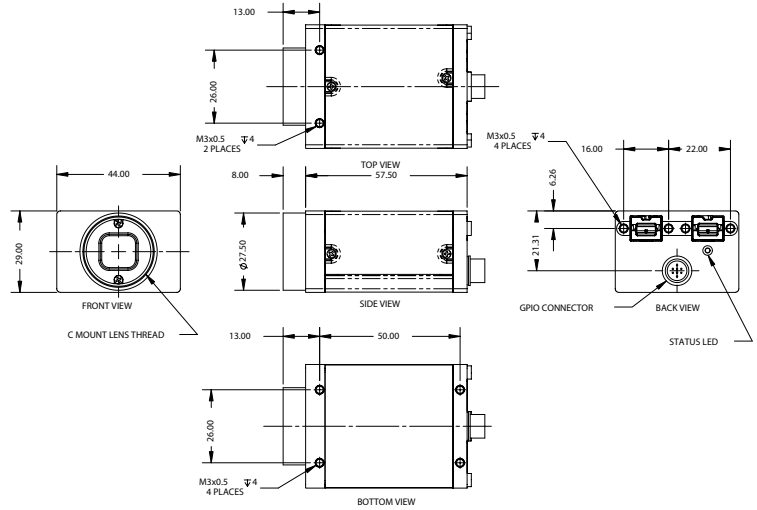

GPIO

Diagram	Pin	Function	Description
	1	IO0	Opto-isolated Input (default Trigger in)
	2	IO1	Opto-isolated Output
	3	IO2	Input / Output / RS232 Transmit (TX)
	4	IO3	Input / Output / RS232 Receive (RX)
	5	GND	Ground for bi-directional IO, V _{EXT} , +3.3V pins
	6	GND	Ground for opto-isolated IO pins
	7	V _{EXT}	Allows the camera to be powered externally
	8	+3.3V	Power external circuitry up to a total of 150mA
To configure the GPIO pins, consult section 3.4 "General Purpose Input / Output" of the Flea3 Technical Reference Manual			

SPECIFICATIONS

	GS2-FW-14S5M / C
Image Sensor Type	Sony progressive scan interline transfer CCD with square pixels and global shutter
Image Sensor Model	Sony ICX285 2/3"
Max Res and Max Frame Rate	1384 x 1036 at 30 FPS
Pixel Size	6.45 x 6.45 μm
Analog-to-Digital Converter	Analog Devices 14-bit ADC
Video Data Output	8, 12, 16 and 24-bit digital data
Image Data Formats	Y8, Y16, Mono8, Mono12, Mono16, Raw16 (all models) RGB, YUV411, YUV422, YUV444, Raw8, Raw12, Raw16 (color model)
Digital Interface	IEEE 1394b 800 Mbit/s interface with screw locks for camera control, data, and power
Partial Image Modes	Pixel binning and region of interest modes available via Format_7
General Purpose I/O Ports	8-pin GPIO connector for power; trigger; strobe; PWM; and serial I/O 1 opto-isolated input, 1 opto-isolated output, 2 bi-directional I/O pins
Gain Control	automatic / manual / one-push gain modes, programmable via software, -3.6dB to 24dB
Shutter Speed	automatic / manual / one-push modes, programmable via software, 0.03ms to 330s (extended shutter mode)
Synchronization	via external trigger; software trigger (on same bus) or free running
External Trigger Modes	External hardware or software trigger Multiple exposure, bulb shutter, multi-shot, and overlapped trigger modes
Voltage / Power	Voltage: 8-30V Power: less than 2.5W
Dimensions (W x H x L)	44mm x 29mm x 58mm (not including lens holder and GPIO connector)
Mass	104 grams (without optics)
Memory Storage	32MB frame buffer, 512 KB non-volatile data flash
Memory Channels	2 memory channels for custom camera settings
Camera Specification	Complies with IICD 1.32
Lens Mount	C-mount
Emissions Compliance	CE, FCC, RoHS
Operating Temperature	0° to 45°C
Storage Temperature	-30° to 60°C
Vibration Resistance	10 G (14 Hz to 200 Hz)
Status Monitoring	Bi-color LED that can be red, green, or yellow
Warranty	2 Years