

LADYBUG®3 SPECIFICATIONS

SPECIFICATION	DESCRIPTION
Image Sensor Model	Six (6) Sony ICX274 1/1.8" progressive scan color CCDs (five in horizontal ring, one on top)
Maximum Resolution	1600(H) x 1200(V) (each sensor)
Shutter Type	Global Shutter
A/D Converter	Analog Devices 12-bit ADC
Video Data Output	8-bit raw Bayer (color) digital data
Digital Interface	9-pin 1394b (FireWire) 800Mb/s interface for camera control, power and video data, locking screws guarantee secure connection
Max Frame Rates	15 FPS JPEG compressed, 6.5 FPS uncompressed, 32 FPS (Mono8, color-separated, half-height, JPEG compressed)
Partial Image Modes	region of interest modes via Format_7, programmable via software
Optics	six (6) high quality 3.3 mm focal length microlenses
GPIO Port	8-pin GPIO connector for external trigger, strobe, serial port or external power
Camera Settings Control	shutter, gain, white balance, gamma and JPEG compression, are programmable via software
Voltage Requirements	8-30V via the IEEE-1394b interface
Power consumption	7.2 W at 12V
Case Material	Machined aluminum housing, anodized red
Case Type	Single unit, water resistant
Dimensions	122 mm x 141 mm
Mass	2416 grams (head unit)
Camera Specification	IIDC 1394-based Digital Camera Specification v1.31
Emissions Compliance	complies with CE rules and Part 15 Class A of FCC rules

OUTPUT IMAGE FORMATS

The Ladybug3 captures images in Format_7 custom image mode by default. The table below outlines the Format_7 modes that are supported. The implementation of these modes and the frame rates that are possible are not specified by the IIDC, and are subject to change across firmware versions.

MODE	PIXEL FORMAT	MAX FPS
0	Raw8	6.5
2	Raw8, Half-height	13
3	Mono8, Color-separated, Half-height, JPEG-compressed	32
7	Mono8, Color-separated, JPEG-compressed	16

STATUS LED

Maximum red (Initial connection)	Initial startup. On until camera is initialized.
Maximum red (During operation)	Condition 1: Bus Rest. On for 0.66s. Condition 2: Power failure. On until power-up via CAMERA_POWER 0x610.
Dull Red	Configuration error.
Dull Green	Camera is idle.
Bright Green	Firewire activity. On for 0.5s during activity.
Dull Yellow	Powered down.
Bright Yellow	Powered down + activity. On for 0.5s during activity.
Red/Green flashing	Camera firmware is being updated. Flashes at 5Hz.

4-LEGGED DESKTOP MOUNT

The case is equipped with the following mounting holes:

- Two (2) M3x0.5mm mounting holes on the top of the case
- Four (4) M3x0.5mm mounting holes on the bottom of the case that can be used to attach the camera directly to a custom mount or to the Ladybug3 tripod mounting bracket (coming soon)
- The Ladybug3 mounting support and base comes with the Development Accessory Kit, or can be purchased separately by contacting sales@ptgrey.com

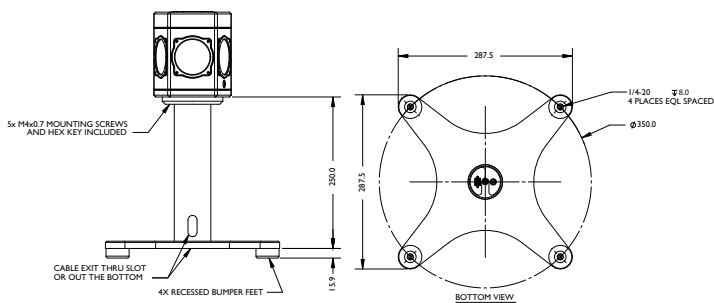

TRIPOD ADAPTER

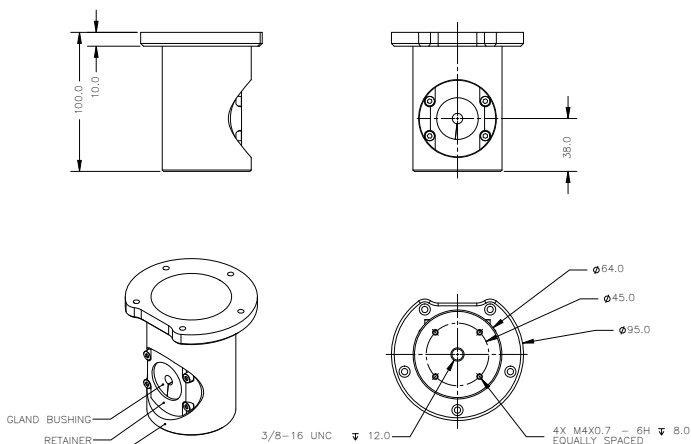

Getting Started

LADYBUG®3 1394b Spherical Vision System

The following items are included with your Ladybug3 Development Accessory Kit

- FWB-PCIE-01: single bus 1394b PCI Express card
- ACC-01-2017: 10 meter 1394b cable
- FWB-EC-2PORT: 1394b ExpressCard for laptops
- ACC-01-9003: power supply for ExpressCard
- Tripod Adapter
- 4-Legged Desktop mount
- Ladybug3 Getting Started Manual
- Ladybug SDK (C/C++ API and device drivers) CD



TECHNICAL DRAWINGS

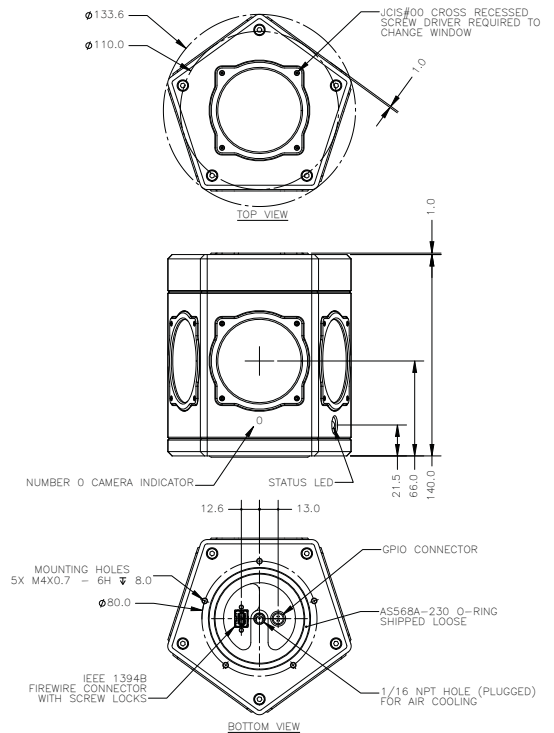

CONTACTING POINT GREY RESEARCH

Email:

For all general questions about Point Grey Research please contact us at info@ptgrey.com.
For technical support (existing customers only) contact us at www.ptgrey.com/support/contact/.

Main Office:

Mailing Address:
Point Grey Research, Inc.
Richmond B.C. Canada
12051 Riverside Way
V6W 1K7

Tel: +1 (604) 242-9937
Toll Free (N.America only): +1 (866) 765-0827
Fax: +1 (604) 242-9938
Email: sales@ptgrey.com

Knowledge Base:

Find answers to commonly asked questions in our knowledge base at www.ptgrey.com/support/kb/.

Downloads:

Users can download the latest manuals and software from www.ptgrey.com/support/downloads/.

1 Installation

1. Recommended System Configuration

OS	CPU	RAM	VIDEO	PORTS
Windows XP SP1 or Vista	2Gz Dual/Quad Core	2GB	NVIDIA 512mb	IEEE-1394b

- Windows XP or Vista
- Point Grey FirePRO driver
- Intel Core2 Duo or Quad processor or compatible processor
- 2 GB of RAM
- NVIDIA video card with 512 MB RAM
- IEEE-1394b PCI Express interface card
- Striped disk RAID array to store streaming data at more than 80MB/sec
- Microsoft Visual Studio 2005 (to compile and run example code)

2. Electrostatic Precautions and Camera Care

- Users who have purchased a bare board camera should:



- Either handle bare handed or use non-chargeable gloves, clothes or material. Also use conductive shoes.
- Install a conductive mat on the floor or working table to prevent the generation of static electricity.



- When handling the camera unit, avoid touching the lenses. To clean the lenses, use a standard camera lens cleaning kit or a clean dry cotton cloth. Do not apply excessive force.

- To clean the imaging surface of your CCD, follow the steps outlined in www.ptgrey.com/support/kb/index.asp?a=4&q=66.
- Extended exposure to bright sunlight, rain, dusty environments, etc. may cause problems with the electronics and the optics of the system.
- Avoid excessive shaking, dropping or mishandling of the device.

2 Installation

3. Install the IEEE-1394b PCIe card (Desktop) or IEEE-1394b Express Card (Laptop)

- Turn computer off and place the IEEE-1394b PCI card in an open PCI slot (desktop) or place the IEEE-1394b PCI-Express card in an open PCI-Express slot (laptop).

FirePRO IEEE-1394b PCIe card (Desktop)

IEEE-1394b Express card (Laptop)

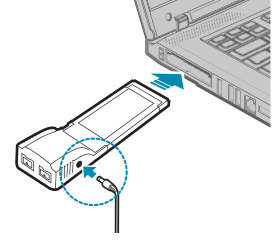
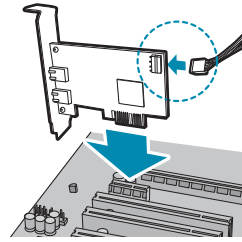

- Connect the 4-pin connector on the card to the PC power supply (desktop) or connect the power adapter to the Express Card (laptop).

- Turn the computer back on and log into Windows.
- In most cases, the Windows IEEE-1394 drivers will be automatically installed for the card, with no user input required. However, in some cases the **Found New Hardware Wizard** will appear. Follow the prompts given by the Wizard to install the card.

- Open Windows Device Manager by going to the **Control Panel > System > Hardware tab > Device Manager**. Ensure the PCI card is properly installed as an **IEEE 1394 Bus host controller**.

4. Install the Ladybug Software and Drivers

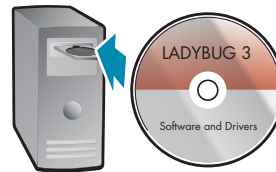

- Insert the Ladybug software CD-ROM. If the Installation Wizard does not automatically run, browse to your CD-ROM directory and run the **setup.exe** file.

- Follow the installation instructions to install the software.



IMPORTANT NOTE for Windows XP and Vista Users

- A dialog will appear asking if you want to install Point Grey's FirePRO driver. If you are running Vista, XP SP2, or XP SP3, users must install and use the FirePRO driver to achieve S800 speeds. For more details, refer to the following Knowledge Base articles: <http://www.ptgrey.com/support/kb/index.asp?a=4&q=258> <http://www.ptgrey.com/support/kb/index.asp?a=4&q=171>

3 Installation

5. Installing the Tripod Adapter (optional)

- The tripod adapter for the Ladybug3 attaches to the bottom of the camera. Feed and secure the IEEE-1394b cable through the adapter. Then plug the cable into the camera 1394b connector and screw the adapter to the bottom of the Ladybug3.

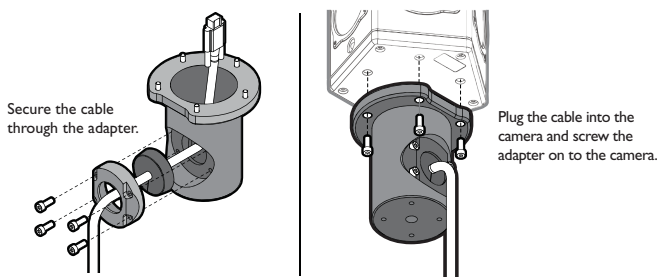

6. Connect the 1394b PCI Card and Cable to the camera

- Plug the IEEE-1394b cable into the 1394b PCI card (desktop) or Express card (laptop).

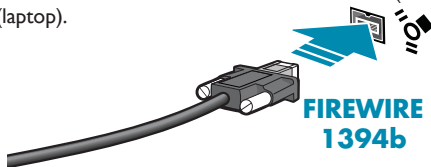

- If the Microsoft Windows **"Found New Hardware Wizard"** appears, proceed to Step 7. Otherwise, proceed to Step 8.

7. Configure the Ladybug Driver

- Click **"Install from a list or specific location"** and click **"Next"**.
- Select **"Don't search. I will choose the driver to install"** and **"Next"**.
- Click **"Have Disk"** and browse to **C:\Program Files\Point Grey Research\PGR Ladybug\driver\signed\<your platform>** click **"Open"**, then **"OK"**.
- Select the camera model, then click **"Next"**. See the following Knowledge base article for further information: <http://www.ptgrey.com/support/kb/index.asp?a=4&q=258>
- You will be prompted to continue installation - click **Continue Anyway** then **Finish** to complete installation. Check the Device Manager to confirm that installation was successful.

8. Test the Installation using LadybugCapPro

- From the **Start** menu, select **All Programs > Point Grey Research > PGR Ladybug > LadybugCapPro.exe**.
- The **Welcome** dialog opens, and it will display a choice of starting a camera, or loading a previously recorded stream file. Select **Start Camera**.
- The **Select Camera** dialog opens. This dialog allows you to view a list of all the currently connected Ladybug cameras across all IEEE-1394 buses, and select one to control and view images from.
Note: Setting isochronous or asynchronous transfer speeds is recommended for advanced users only. If in doubt, use the default settings.
- To begin grabbing images, select a camera and click **OK**.
- The first time **LadybugCapPro** runs, it will warn that a set of alpha masks must be generated then prompt you for the blending width (overlap in pixels between cameras). For simplicity, use the default blending width and select **OK**.
- After selecting a blending width, the **LadybugCapPro** Main Window opens in live image-grabbing mode.

4 Troubleshooting

- The Ladybug User Guide (**Programs > Point Grey Research > PGR Ladybug > Documentation**) provides detailed installation information. Our on-line **Knowledge Base** (<http://www.ptgrey.com/support/kb/>) also addresses the following problems:

- Article 21: Troublesome hardware configurations
- Article 91: PGR camera not recognized by system and not listed in Device Manager
- Article 258: Which Point Grey camera driver should I use?
- Article 171: Performance of 1394 devices may decrease after installing Windows XP SP2
- Article 188: Image data acquired by my camera is corrupt and displayed images are broken

5 Other References

- The Ladybug User Guide (**Programs > Point Grey Research > PGR Ladybug > Documentation**) provides other references.
 - Ladybug SDK Help
 - Ladybug3 Technical Reference
- Knowledge Base Articles:
 - Article 250: Overview of the Ladybug image stitching process
 - Article 264: Overview of multithreading optimizations in Ladybug library.
 - Article 285: Which versions of Visual Studio can be used to build applications using the FlyCapture or Ladybug SDK?
 - Article 288: Ladybug JPEG image quality and buffer size settings.
 - Article 302: Using the Ladybug3 in a mobile setting
 - Article 337: Working with signed and unsigned camera drivers